

SUSSEX INDUSTRIAL HISTORY

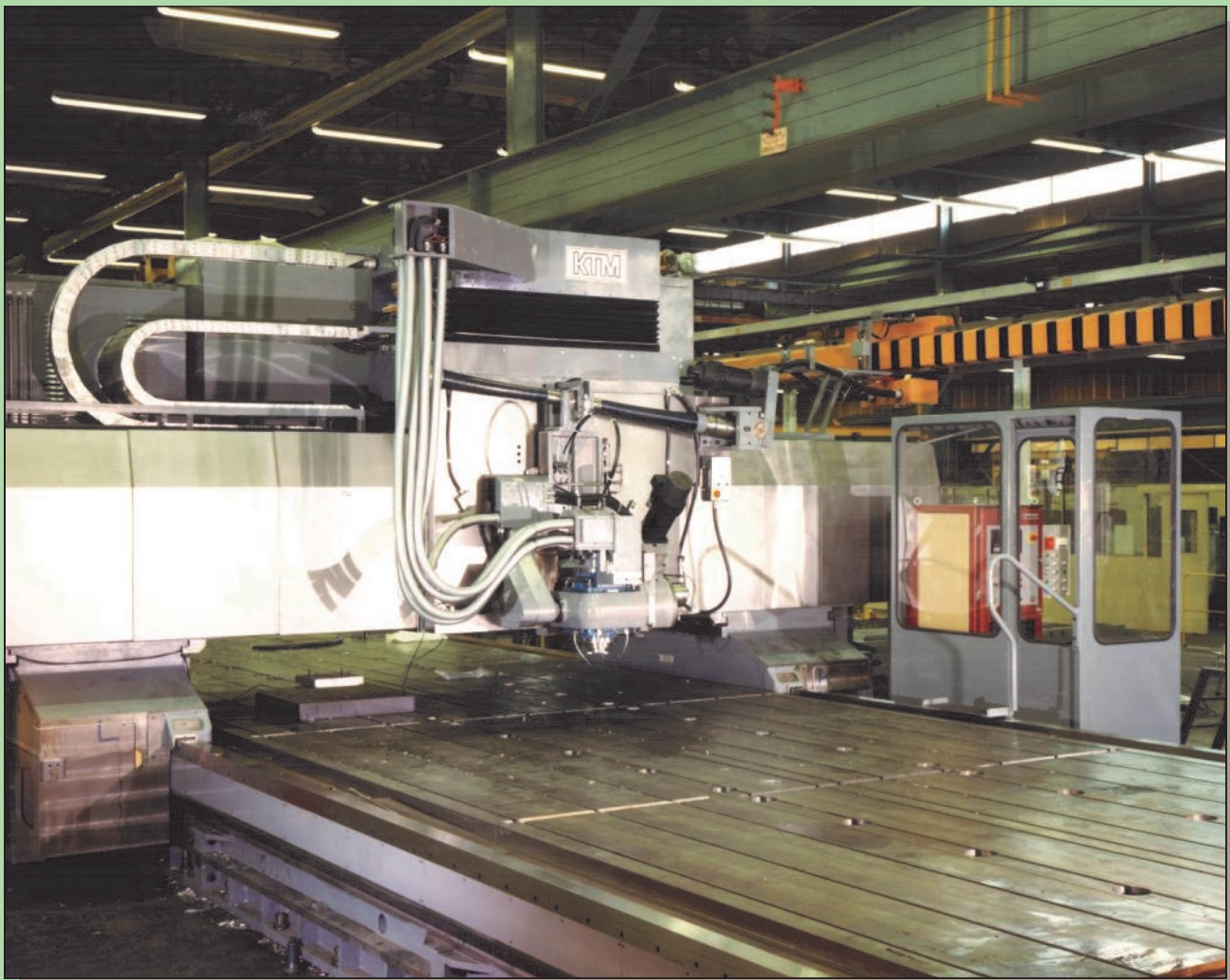

NUMBER 41

2011



**The Arun Navigation and Hardham Tunnel
Sources for Sussex Mills, Millers and Millwright Research
The Canal Pumping Station at Ford
Hollingbury and the Airbus
Turnpikes to Brighton**

£5.00

SUSSEX INDUSTRIAL HISTORY

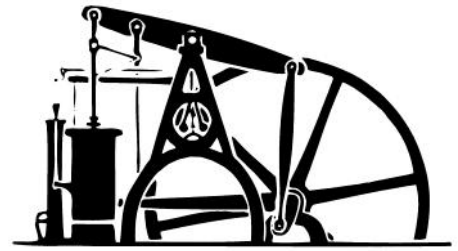

Journal of the Sussex Industrial Archaeology Society

AIA Publication Award 2010

FORTY-ONE

2011

CONTENTS

	Page
THE ARUN NAVIGATION AND HARDHAM CANAL TUNNEL P. A. L. Vine	2
SOURCES FOR SUSSEX MILLS, MILLERS AND MILLWRIGHT RESEARCH Bob Bonnett	15
THE CANAL PUMPING STATION AT FORD Alan H. J. Green	24
HOLLINGBURY AND THE AIRBUS Peter Groves	33
TURNPIKES TO BRIGHTON Brian Austen	39
Publications	60

Cover illustration — the 200 Series Maxetrace CNC machine at the Hollingbury factory of KTM

Edited by Dr. Brian Austen, 1 Mercedes Cottages, St. John's Road, Haywards Heath, West Sussex RH16 4EH (tel. 01444 413845, email brian.austen@zen.co.uk). Design and layout by Alan Durden. The Editor would be interested to hear from prospective contributors of articles of any length. Shorter notices can be included in the Society's *Newsletter* which is issued four times a year.

The annual subscription to the Sussex Industrial Archaeology Society is £10 payable on 1 April. Life membership is available at fifteen times the annual subscription. Members are entitled to copies of the *Sussex Industrial History* and the *Newsletters* without further charge.

Membership enquiries to the Hon. Secretary, R.G. Martin, 42 Falmer Avenue, Saltdean, Brighton BN2 8FG (tel. 01273 271330, email sias@ronmartin.org.uk). Website: www.sussexias.co.uk

ISSN 0263 5151

© SIAS on behalf of the contributors

THE ARUN NAVIGATION AND HARDHAM CANAL TUNNEL

A Successful Eighteenth Century Enterprise

P. A. L. Vine

The River Arun has for centuries been the most important of the Sussex waterways. There seems little doubt that the river was partly navigable at the time of the Norman Conquest. While authorities are at variance upon whether Arundel boasted any river traffic before this date, the town is referred to as a port in Domesday Book time ('portum aquae et consuetudinem navium'). It is reported by various chroniclers that in about 1070, Roger de Montgomery, a Norman nobleman, created Earl of Arundel by William I for his help at Hastings, imported small square blocks of Caen stone from Normandy for refacing the castle keep. Hadrian Allcroft presents a strong case for accepting Ford as the then port of Arundel, since the tide probably flowed no higher than this point before 1300 and the crossing-point would have hindered the passage of boats which were heavily laden. Furthermore, the river would at that time have flowed an inconvenient half a mile east of where Arundel Bridge now stands.¹

Arundel grew in importance. In 1295 two Members were returned to Westminster. By the turn of the fourteenth century its markets and fairs were firmly established and on the hillside between castle and marsh 94 houses and 32 stalls were clustered together. Not, however, until the latter half of the sixteenth century were serious attempts made to improve the navigation of the river. In 1544 Henry Fitzalan had succeeded to the earldom at the age of 31 and it was he who, in the course of the next 30 years, set out to make the town a port for sea-going vessels and to reduce the widespread flooding.

This work must have been a gigantic operation at the time, but it was surprisingly successful. The channel to the sea was cleared and widened and the river embanked as far up as North Stoke before the end of Henry VIII's reign (1547). The course of the Arun at Arundel was altered so that the river flowed to the edge of the town and by 1550 timber was being exported from the newly-built wharves. During the early part of Queen Elizabeth I's reign, the work of making a new entrance - the narrow one

shown on Palmer's map - to the river at Littlehampton was completed. The task of improving the upper reaches was then begun.

The water bailiff's book of the River Arun is the only extant source of information regarding the early navigation of the Arun.² Anciently, wrote the bailiff,* the navigation began at a place in the river called 'Turning-stream', just below Stopham Bridge where the Arun and Rother rivers joined, but that nowadays (1637) it started at Pallingham Quay, the river being cleared about the beginning of Queen Elizabeth's reign (1558) by Fitzalan for moving timber down from Pallingham by barge. The river at that time was only tidal as far as Houghton. Boat traffic beyond that point was hampered by as many as 29 'weares'; many of these were decayed, and were only passable between sunrise and sunset. It was the water bailiff's responsibility to ensure that during daylight these penstocks or gates were kept open by the fishermen.

Daniel Defoe on his Tour through Great Britain mentioned in 1722 that Arundel was a town 'decayed' but that great quantities of large timber were shipped from the town to the shipyards along the Thames and up the Medway since it was esteemed the best from any part of England. Although the opening of the new harbour at Littlehampton in 1736 caused further consideration of plans to improve the river navigation, it was not until the 1780s that the local landowners commissioned James Edwards to survey the Arun up to Newbridge, Wisborough Green. Consequently Henry Digance of Arundel and others presented a petition to the House of Lords for a parliamentary bill to improve the river on the grounds that it was much obstructed by shoals which made it 'inconvenient' for the carriage of merchandize.³

Leave was granted to bring in a bill to improve the navigation above Houghton and to authorize the construction of two canals between Coldwaltham and Hardham, and between Jupp's Mead by Pallingham wharf and Newbridge. However, the inhabitants of Pulborough and adjacent parishes protested against the proposed toll to be levied on goods passing between Houghton Bridge and Pallingham since no toll was then payable and 'repeated declarations had been made that none was intended to be imposed'.

* Probably William Barttelot (1592-1667) who lived at the Manor House in Stopham

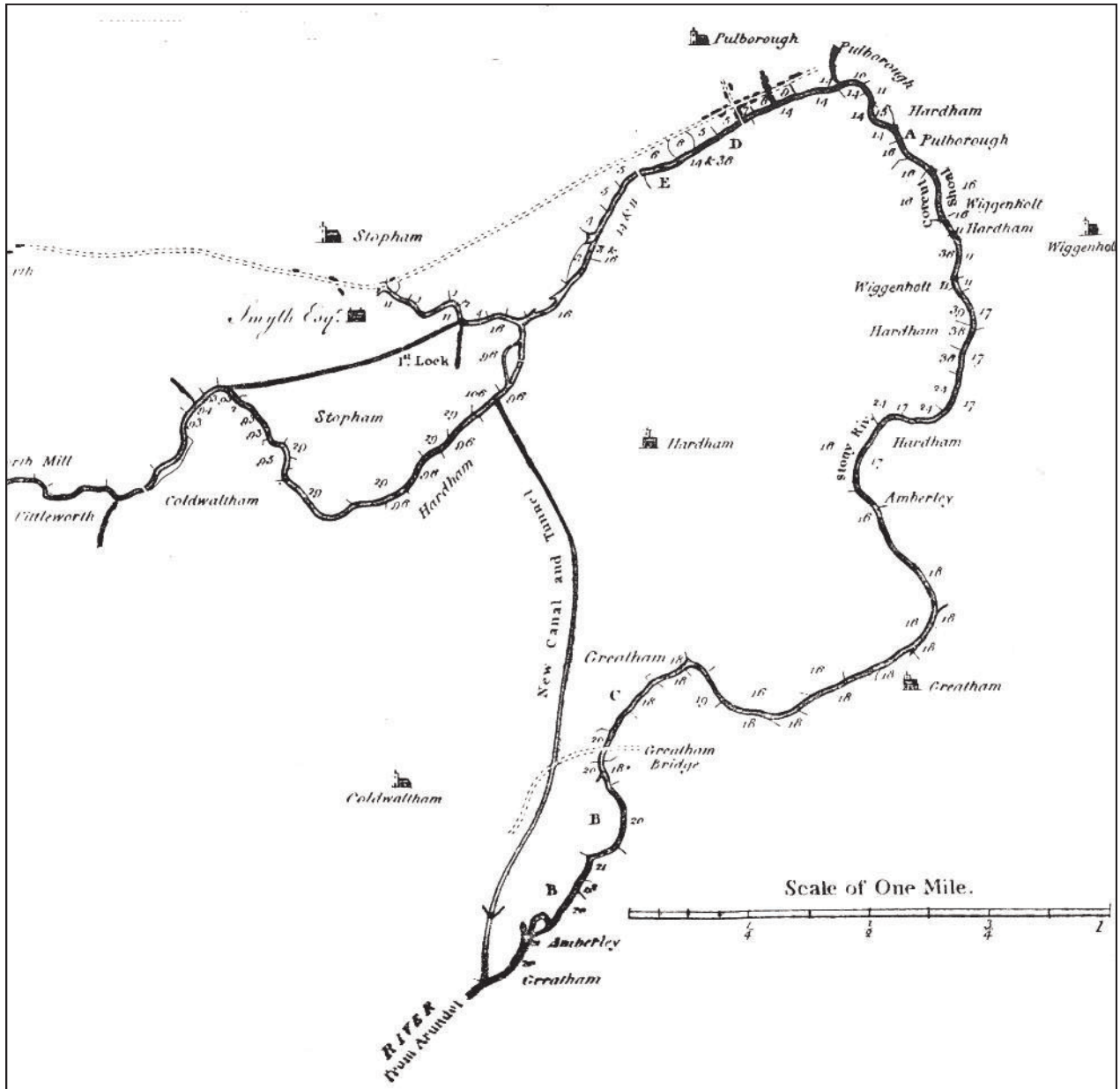

Fig. 1 Plan of the Coldwaltham Cut and the River Arun, 1791

The petitioners won their main point and although the Arun Navigation Act, passed in May 1785, authorized the improvement of the tide-way above Houghton Bridge, it specified that the navigation of the river between Houghton and Pallingham was to remain free of toll “even if locks have to be, in time, erected between Houghton and Greatham Bridge”. The tolls to be charged between Pallingham and Houghton fell into two classes. All goods, including coal, corn, timber and general merchandize, were to be charged 9d a ton, but firewood, chalk and dung only 6d a ton. From Pallingham to Newbridge this was to be 2s 3d a ton, except for firewood 1s a ton and chalk 6d a ton. Unusually the Act set out the maximum carriage charges that could be levied by the carriers to prevent impositions. Bargemen

charging more could be brought before a magistrate and fined up to £5.

James Edwards began work on the Arun Canal in August 1785 by which time £7,000 of the £10,000 authorized capital had been subscribed.⁴ Two years later the upper navigation was completed but in the autumn construction of the tunnel section had to be temporarily suspended until a mortgage on the tolls could be raised.

On reflection it would seem to have been an extravagant proposition to build a tunnel when a deep cutting could have sufficed. The Act makes no mention of a tunnel, only the cut and its attendant bridge. It seems probable that initially only a cutting was envisaged to link Greatham with Hardham, and

it was only decided to build the tunnel because the adjacent landowners would not agree. Not only would the excavations have been considerable, but a bridge would have been needed to carry the Pulborough to Coldwaltham Road. It was probably only as a last resort that the company, rather than abandon their plans, decided to go ahead with the tunnel whose expense was seemingly disproportionate to the estimated total cost of the lower navigation.

Prior to the opening of the navigation through Hardham Hill in 1790, the public were advised that a twice-weekly goods service between London and Arundel by way of Newbridge would commence in June. Heavy goods were to be charged 2s 3d a cwt, light goods and liquors 2s 6d.⁵ More attractive barge rates included reductions if the company's wharves* were used and free passage granted through the tunnel if a ticket was obtained from the first lockkeeper encountered. Barge owners were to be allowed to pay their dues quarterly. Ten tons or more of sea gravel which had to be taken from below the West Pier at Littlehampton was to pay only one shilling toll if the materials were to be used to repair the public roads leading to Newbridge wharf.⁶

The official opening of the Lower Arun Navigation was celebrated in grand style. It took place on Saturday 14 August 1790. The *Sussex Weekly Advertiser* heralded the occasion by recording how the proprietors embarked on their gaily-decorated barge at Waltham† lock in the presence of hundreds of spectators. Attended by a band they proceeded through the tunnel to Stopham Wharf. Here a "cold collation and plenty of wine were provided while the workmen emptied two or three hogsheads of strong beer given to them by their masters."

An onlooker reported that

"The opening and passing through the Tunnel, at Hardham Hill, was a novel, and interesting sight to me. The day was remarkably fine. About one o'clock the first barge gave the signal for starting by a discharge of cannon mounted thereon; the barge, was followed by two more, very much crowded with company, both of ladies and gentlemen."

In the first of these, was a band of music; at the entrance the first barge again fired her guns, and then the procession proceeded through the subterranean

passage; the gloominess of the scene, and the faint sound of the music, were altogether charming; at coming out of the tunnel, the guns again saluted, the colours were again hoisted, and the barges and company, passed through the locks, and so to Stopham."

"Here, booths were pleasantly placed, wherein the company dined; after which contest between some barges took place which included a guinea being awarded to the barge loaded with 30 tons of chalk which passed through the tunnel in the shortest time. Much jollity and humour, mark'd the evening, and the welkin resounded with the cheers of the multitude and the noise of the cannon."

There is one item in the detail of the proceedings which is puzzling. The account states that after giving the tunnel's length as about 440 yards, reference is made to 'a small opening to the surface of the hill about three parts of the way through'. According to the 1876 Ordnance Survey the correct length is 375 yards. It is possible an earlier collapse of the entrance at the southern end required it to be opened up and thus shortened by 60 yards or so, but there is no reference to such an occurrence in the company's minutes.⁷

The celebrations were no sooner over than difficulties arose. The *Lewes Record* reported that some of the Arun proprietors were attempting to reduce the bargemen's wages on the grounds that now 'their work is more certain and easy, and therefore cheaper'.⁸ This the workmen strongly refuted. They were vexed. Going through the tunnel was, they said, no easement to them. Young Andrews even wagered a guinea that he could round the old river sooner than an equally loaded barge via the tunnel. The bargees referred to the late rejoicings at the tunnel's opening as 'Belshazzar's Feast' and wrote in large letters on a board on Stopham Wharf "Mene, mene, tek el upharsin".⁹ It was even suggested that the miller at Fittleworth was prepared to shut up his sluices and, by suddenly opening them, ruin the works. The rift blew over and in October four proprietors (William Tate, the Digances and Richard Smart) announced "in consequence of the great advantage and convenience obtained by navigating goods through Hardham Tunnel", barges carrying 30 tons would not in future be charged more than 2s 6d per load from Newbridge to Littlehampton.¹⁰

By 1791 water communication was open from the sea to Arundel for vessels up to 200 tons and for barges as far as Newbridge. However, the river

* Watersfield, Stopham and Pallingham

† Former name of Coldwaltham



Fig. 2 The entrance to the Coldwaltham Cut from the River Arun, 1951.



Fig. 3 The entrance to Coldwaltham Lock, 1941. The ruins of the lock-house remained visible until the 1950s. The cut was enfilled by the river authority in the 1970s.

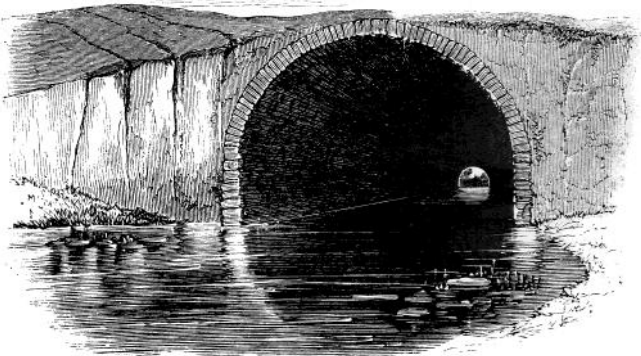

Fig. 4 Artist's drawing of the southern entrance to the tunnel, 1868. Tunnel lock can be seen at the far end of the tunnel.



Fig. 5 The South Entrance to the tunnel as it appeared in 1949.



Fig. 6 The North Entrance and Tunnel Lock from a drawing by Thomas Evershed, 1843. Observe the tree trunks used as crude beams for the lock gates.



Fig. 7 The remains of the upper gate of Tunnel Lock, 1951



Fig. 8 The North Entrance, 1952. The concrete dam was newly erected on the site of Tunnel Lock.

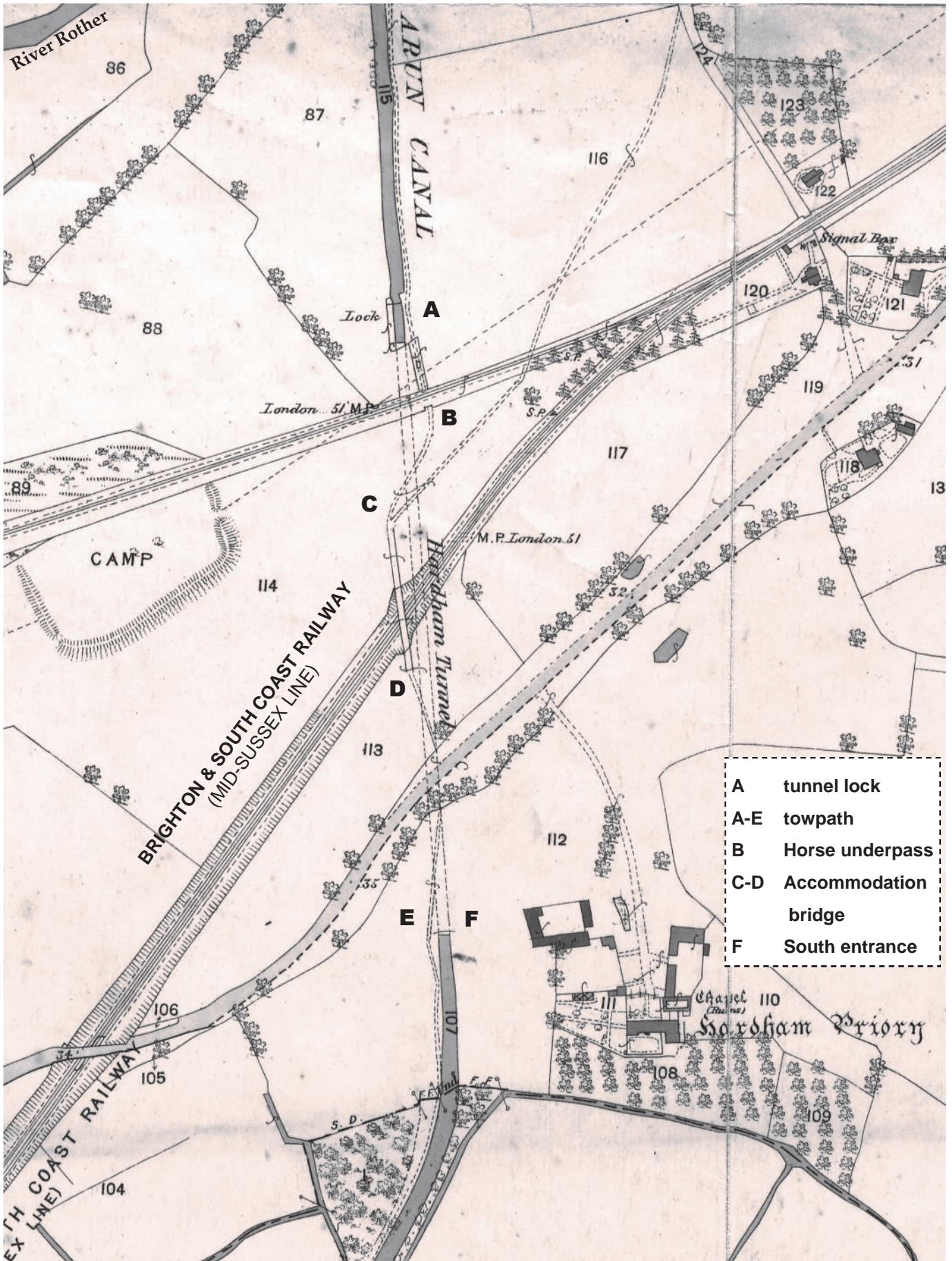

- A tunnel lock
- A-E towpath
- B Horse underpass
- C-D Accommodation bridge
- F South entrance

Fig. 9 Ordnance Survey 25" map, 1876 edition, showing Hardham Tunnel (not reproduced to scale). The underpass for barge horses passed beneath the Petworth railway line opened in 1859. (Courtesy West Sussex Record Office)

between Arundel and Pallingham, a distance of 18¼ miles, remained a public navigation free of toll. There was no tow-path; barges either sailed or were punted up and down the river with the tide. The journey from Littlehampton to Newbridge took about two and a half days, although six hours were saved if Hardham Tunnel was used. Most of the barges were sprit sailed and could carry in excess of 30 tons, although the loads were related more to draught than to capacity, being dependent on the rain rather than the tide on the upper reaches of the river.

Not surprisingly, the Arun proprietors made no effort to maintain the river above Greatham, and it was this failure that prompted the merchants and inhabitants of Pulborough to petition the House of Commons in 1791 "to acquaint the Honourable House that the river is now in a worse state for the purpose of navigation than at the time the Act was obtained (1785) and unless provision be made for the speedy and effectual carrying into execution the purposes intended by the said Act, your petitioners and many persons residing nearby must be very great sufferers and their trade materially injured." It was this fact that had persuaded Lord Egremont to consider initially including the River Arun between Greatham and Stopham in his bill for the Rother Navigation and the reason for William Jessop's survey in 1789.¹¹

The passing of the Rother Navigation Act of 1791 brought little satisfaction to the proprietors of the Arun Navigation. Although they anticipated that some revenue would accrue from Rother barges using the Coldwaltham Cut, it was unlikely to be sufficient to defray the expense of the Arun's statutory duty to maintain the tideway.

Until the opening of the Wey & Arun Junction Canal most of the Rother's traffic originated from, or was destined to, the Arun Navigation. Thus the Rother's dependence on the smooth running of the Arun was as much its concern as it was that of the Arun proprietors who, one would have hoped, would have been in agreement with the plans and projects of Lord Egremont. Unfortunately this was not the case.

In the first place the Arun proprietors were primarily local merchants investing in what they hoped would become a prosperous enterprise, whereas the Earl was more concerned with the public good and the improvement of his estates.

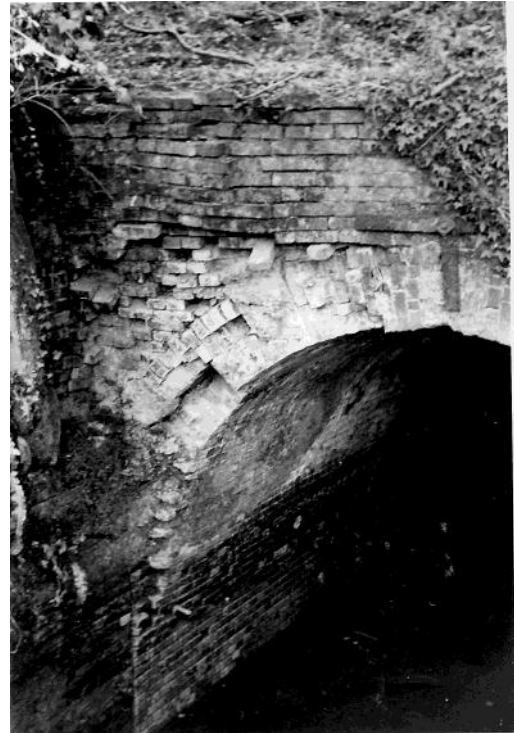

Fig. 10 Deteriorating façade of the northern entrance, 1952.

Secondly, the company was in serious financial difficulty since the cost of building the navigation had greatly exceeded the estimate. Only £7,000 of the authorised share capital of £10,000 had been raised and some £9,000 had had to be borrowed on mortgage of the tolls to complete the navigation.¹² Thirdly, the estimated carriage of 30,000 tons a year had yet to materialise. Traffic during the first twelve months of full operation only amounted to 14,000 tons, which yielded an annual income barely sufficient to meet the running expenses and to pay the interest on the loans. The Arun Navigation company's proposals to further extend their navigation without advising Lord Egremont indicates that the relationship between the company and the peer was not the best.

Early in 1792, concern was expressed by Lord Egremont's advisers at talk of the Arun proprietors petitioning Parliament for a further Act. At their meeting the previous December, the latter had in fact agreed to apply for a bill to build a branch canal from above Orfold Lock on the Arun Canal. Henry Tripp, Lord Egremont's London attorney, wrote to his brother James Upton Tripp, who was the Sussex agent, on 31 January 1792, to say that he would try and obtain any facts or knowledge of the intentions of the Arun proprietors. The Arun's clerk, William Carleton, wrote on the day their petition was

presented to the House of Commons to say that the Arun proprietors did not “mean in any way to interfere with Lord Egremont's navigation” and that the present application was to extend their navigation to Kirdford.

Even so, Henry advised his brother that great care and circumspection were necessary on the part of his lordship during the progress of this bill through the two Houses: “I think we know enough of the Arun proprietors to be assured that they may say one thing and mean another.”

Henry Tripp was soon proved right. The Arun proprietors not only petitioned the House of Commons on 28 February 1792 for an Act to extend their navigation, but they had also included in the petition a request for powers to continue the cutting from Hardham Tunnel to the Rother Navigation above Stopham Lock.

The reason why the Arun proprietors had had to resort to this ruse was the simple fact that they were heavily in debt and were losing money because the bargemasters were unwilling to pay to use the tunnel, when for the sake of an extra six hours they could, if they had a light load, use the old river by Pulborough toll free - a stretch of navigation which, under the terms of their Act, the Arun proprietors had to maintain at their expense and which, by doing so, robbed them of their income - or so they claimed. Inducements introduced in 1789 to encourage traders to use the tunnel by offering toll-free passage if their barges used the company's wharves, had met with a limited response.



Fig. 11 The entrance to Hardham (Neil's) Lock, 1889

The Arun proprietors proposed to continue the Coldwaltham Cut beyond Hardham Tunnel to join the Rother Navigation above Stopham Lock. However, what seemed a time-saving proposal to save boats bound to Midhurst from locking up and down, was really a device to encourage greater use of the tunnel and to make it less attractive for the Rother barges to avoid paying toll by using the river. The treasurer was authorised to borrow £2,500 for these works at the committee meeting held on 28 February 1792. At their quarterly meeting in March, it was reported that they had already spent more than £16,000 and that they considered his lordship's navigation as a rival interest to theirs and as the principal cause of their present failure.¹³

It is extraordinary that the Arun proprietors, without any consultation with Lord Egremont, should have included in their petition powers to make a collateral cut which would clearly affect Lord Egremont's navigation. Not only was he not consulted, but he was deliberately misinformed that their petition only sought powers for the Kirdford Canal. One can only



Fig. 12 Hardham Lock cottage, 1955. It was demolished in 1957.

Fig. 13 Clements Bridge, Pulborough, drawn here in 1826, was built in the 1790s. Its ostensible purpose was to provide access for cattle to the water meadows, but its low arches suggest that its main object was to discourage barge traffic from using the toll-free river instead of Hardham Tunnel. Pulborough Church is visible at the left.



RIVER ARUN NAVIGATION.

ABSTRACT OF ACCOUNT

For the Year ending the 5th. of December, 1842.

			£.	s.	D.				£.	s.	D.
Balance in Treasurer's hands, 1841.	240	10	3½	Rent and Taxes.	65	17	2½				
1842, Tolls received at Newbridge,	1265	2	6½	Repairs and Incidental Expenses ..	338	14	7½				
Ditto Tunnel	271	0	6½	Clerk, Superintendent, Collector,							
Light Barge Tolls	52	8	0	and Lock Keepers.....	132	16	0				
Rent of Ozier Beds.....	5	0	0	Manual Labour	278	7	8½				
Ditto Dock	10	0	0	Interest at £9. per cent. on each							
Ditto Coal Pens and Lime				Share.....	900	0	0				
Kilns	0	13	0	Balance in the Treasurer's hands							
Year's Rent from Mr. George				£93. 6s. 1½d.—Ditto in the hands							
Sharp	1	5	0	of Mr. Seward (Wharfinger)£50.	143	6	1½				
Craneage Rent.....	4	2	8								
Cottage Rents	8	19	8								
	£1859	1	8½						£1859	1	8½

*36 Names at 9 per cent I have need only 180 £
 in at 5 per cent
 2
 324
 1842 Acc. at 5 per cent
 Sept. 30th £180
 Dec. 8. £180
 £324*

Fig. 14 Arun Navigation accounts, 1842, showing the tolls split between the tunnel and the upper Navigation.

conclude that this degree of antipathy towards the Earl was occasioned, not just by the simple fact that they believed his navigation was detrimental to the success of their own (because he was encouraging the use of the old river via Pulborough rather than through Hardham Tunnel), but to a large degree by the different outlook, on the one hand, of a very wealthy landowner seeking the public good, and on the other, of the local merchants who were naturally more influenced by the profit motive and who had only received an annual return on their original investment of less than 1½% over a period of ten years. The loss to Lord Egremont's navigation would have been minimal and, if cordial relations could have been established, a form of compensation should not have been difficult to reach.

The arguments presented by Egremont in his petition against the Arun proprietors' Bill were that, firstly, he would lose tolls calculated at 3s 8d on every 30 ton load of timber or coal (in other words the toll of 3d a ton-mile for 860 yards); secondly, that if at any time the locks were at fault, his trade on the Rother would be entirely stopped; thirdly, that the navigation of the River Arun between Stopham and Greatham would be materially hurt by opening the lock sluices at Coldwaltham to draw water from the River Rother in dry periods to allow barges to pass through the Tunnel.

In due course, the House of Commons rejected the petition 'for want of the Arun Navigation proprietors' obedience to the orders of this House's provisions to their carrying in their petition'.

There is one other matter which may be relevant. It is the building of Clements Bridge c1793 upstream of Swan Bridge. This triple-arched stone bridge crossed the Arun above what is now the railway bridge at Pulborough. It carried no highway and was only used by cattle, yet its headroom and the river's lack of draught, prevented all but lightly-laden barges from proceeding above Pulborough to the Rother Navigation. Its origin remains uncertain. It is not mentioned in Jessop's reports. Nor is there any

RIVER ARUN NAVIGATION, (Twelve Miles) <i>Tolls to be Charged from the 1st of August, 1856.</i>	
TUNNEL TOLLS.	
PER TON	Passing to and fro, including Coldwaltham Brook ...
	Timber, Bark, Hoops, Coal, Culm, Corn, Lime, and Merchandize Goods 0 0 6
	Large Chalk 0 0 4
	Kiln Chalk, Grit, Ashes, &c. 0 0 3
	Stone for Building 0 0 6
	Stone, Flint, Gravel for Roads, Sand, and all Kinds of Manure 0 0 3
	Corn to Hardham Mill 0 0 3
JAMES POWELL, Clerk.	

Fig. 15 Notice of the Tunnel Toll Rates in 1856. Tolls continued to be collected until 1889.

record of complaints from Lord Egremont himself or by the Rother bargemasters who wished to use the toll free river. Was there, perhaps, an understanding between the Mr Clement who built the bridge (he was a yeoman of Pulborough) and the Arun proprietors? And did Lord Egremont, after he became chief shareholder of the Arun Navigation, not concern himself about the bridge? These points remain unanswered.¹⁴

In 1794 there was the unfortunate discovery that 'some evil disposed persons had opened the cloughs of the lock at Low Mead,' (Hardham), which had drained off the tunnel's water supply 'to the great hurt and injury of the navigation'. In spite of the company advertising a reward of twenty guineas, the identity of the felons was not discovered. The following year the navigation was 'grievously' affected by floods and consideration was given to granting a licence for any person wishing to use the tunnel for alleviating them.

The lock-keepers at Hardham and Coldwaltham kept a daily record of barges passing through the tunnel. Forty tons was the heaviest cargo. An indication of how useful the tunnel was to local trade can be judged from the traffic returns. From 1831 onwards the company recorded separately the tolls of both the tunnel and the Upper Navigation. Those collected for passing through the tunnel amounted to almost a quarter, and in some years a third, of the company's total annual revenue. Unladen barges were listed as 'light' and as laid down in the Act such barges passing though 'all or any' of the locks paid a toll of one shilling in either direction. This sum was payable on both the Lower

and the Upper Navigations and remained unchanged throughout the life of the company.

The importance of the tunnel can be judged by the substantial revenue it contributed to the company's finances. Over 20,000 toll-paying craft passed through during sixty-year period listed below.

Decade	Annual tolls received	Barges laden	Barges light	Tonnage carried
1831-40	£287 p.a.	425	45	11,500
1841-50	£277 p.a.	405	42	11,000
1851-60	£303 p.a.	445	31	12,000
1861-70	£238 p.a.	350	26	6,500
1871-80	£ 93 p.a.	140	11	2,500
1881-90	£ 30 p.a.	100	5	800

Peak traffic on the Arun Navigation was reached in the 1830s when for nine consecutive years the dividend on the £100 shares exceeded 10% and shares fetched up to £200.¹⁵ The individual peak tolls on the tunnel section, £358 in 1858 and £359 in 1862, were due to the extra carriage of building materials and equipment for the two new railway lines.

Examination of the pages of the few surviving daily journals show that, during the six-month period (November 1841 - April 1842), 227 barges passed through the tunnel carrying 5,123 tons, an average barge load of rather more than 23 tons. In addition there were passages made by 137 light barges. In April 1842, 59 barges passed through carrying 1,326 tons of which 684 were coal and 326 chalk. Most of the up craft were destined for the Rother Navigation, the down traffic to be discharged at Arundel or Littlehampton. Twenty-five years later in November 1868 - by which time the annual tolls had dwindled by two thirds while the tunnel was as busy as ever - 36 barges carried 980 tons showing the average cargo to be 27 tons. There were also 26 light barges.

The extension of the railway from Pulborough to Petworth in October 1859 required the single line to cross less than 13 feet above the crown of the tunnel. To avoid steam locomotives frightening the barge horses, an underpass was built to the left of the

tunnel beneath the track. When the time came for the Arun Valley line to be opened in August 1863 an accommodation bridge carried the tow-path over the double line to Arundel. The horse passageway appears not to have been abandoned until later.¹⁶

The only recorded account of a pleasure boat passing through the tunnel was provided by J B Dashwood in July 1867.¹⁷ He, accompanied by Mrs Dashwood and their Pomeranian dog called 'Boz', travelled from the Thames at Weybridge to the Solent via Littlehampton in their Una boat to watch the Naval Review in honour of the Sultan of Turkey's visit.

It was a leisurely voyage. After four days and numerous incidents they reached Stopham Bridge. Here Dashwood recorded how

"about a couple of hundred yards from this spot, the river makes a detour of about five miles round by Pulborough, to avoid which a canal has been cut, passing through the chalk cliff by means of a tunnel.

Arun Canal Tolls			
From May 1 st 1888 to May 1 st 1891 -			
1888			£ 20
May 10	28 tons Hints to Newbridge		14
12	26 - Chalk		13
16	29 Hints		14 6
19	30 - Chalk		15
23	28 Hints		14
30	30 - Chalk		15
June 1	32 - D to Lee Farm		16
5	32 - D		16
11	32 - D		16
16	30 - D		15
20	10 - D		5
	20 - D Newbridge		10
			8 3 6
	Light Barge Tolls		11
			£ 8 14 6
Tolls at the Tunnel			
1888			
Dec 10	23 tons Hints to Westham Brook		5 9
22	37 - Gravel		9 3
1889			
Jan 10	27 - Hints to		6 9
23	22 - D		5 6
29	26 - D		6 6
			1 13 9
	5 light barges		7
			£ 2 0 9

Fig. 16 The last diary entries of traffic on the Arun Navigation, 1888-9

At the entrance of this tunnel we found another small lock, where we parted company with the pony, which had to go over the top, and meet us at the other end. This tunnel is a quarter of a mile long, 13 feet wide, the same in height, and cost £6,000. I punted the boat along by means of the boat-hook against the roof. In the middle it became quite dark, and we could only

just guide our-selves by means of the bright outlet at the end. The roof was covered with stalactites and in places the water fell upon us from crevices above in heavy drops, so that we had to try and steer clear of them where we heard their splashes on the water below. It took about ten minutes to pass through this subterranean passage, and when we emerged on the

other side it was some moments before we became accustomed to the bright light of the day. We were detained here some little while, for the groom had mistaken his way, and did not turn up for about twenty minutes after we got out of the tunnel."

The closure of the Wey & Arun Junction Canal in 1871 caused a substantial decline in traffic and the tunnel tolls dropped from £180 in 1871 to £70 in 1880. In 1885 they were slightly higher than for the Upper Navigation but fell two years later to £10.

In the summer of 1888 a dozen or so 30 ton loads of chalk from Houghton passed up river past Pulborough and up the Arun canal to Lee farm and Newbridge. Only five barges used the tunnel. On 29 January 1889 the last barge ventured through loaded with 26 tons of flints en route to Waltham Brook.

The tunnel was, and continued to be, the scene for many pleasure boating excursions. The visitors book at the nearby Swan Hotel in Fittleworth recorded various incidents. In June 1882, a boating party of six gentlemen rowed up from Arundel to Waltham Lock, ventured through the tunnel and on to the River Rother and

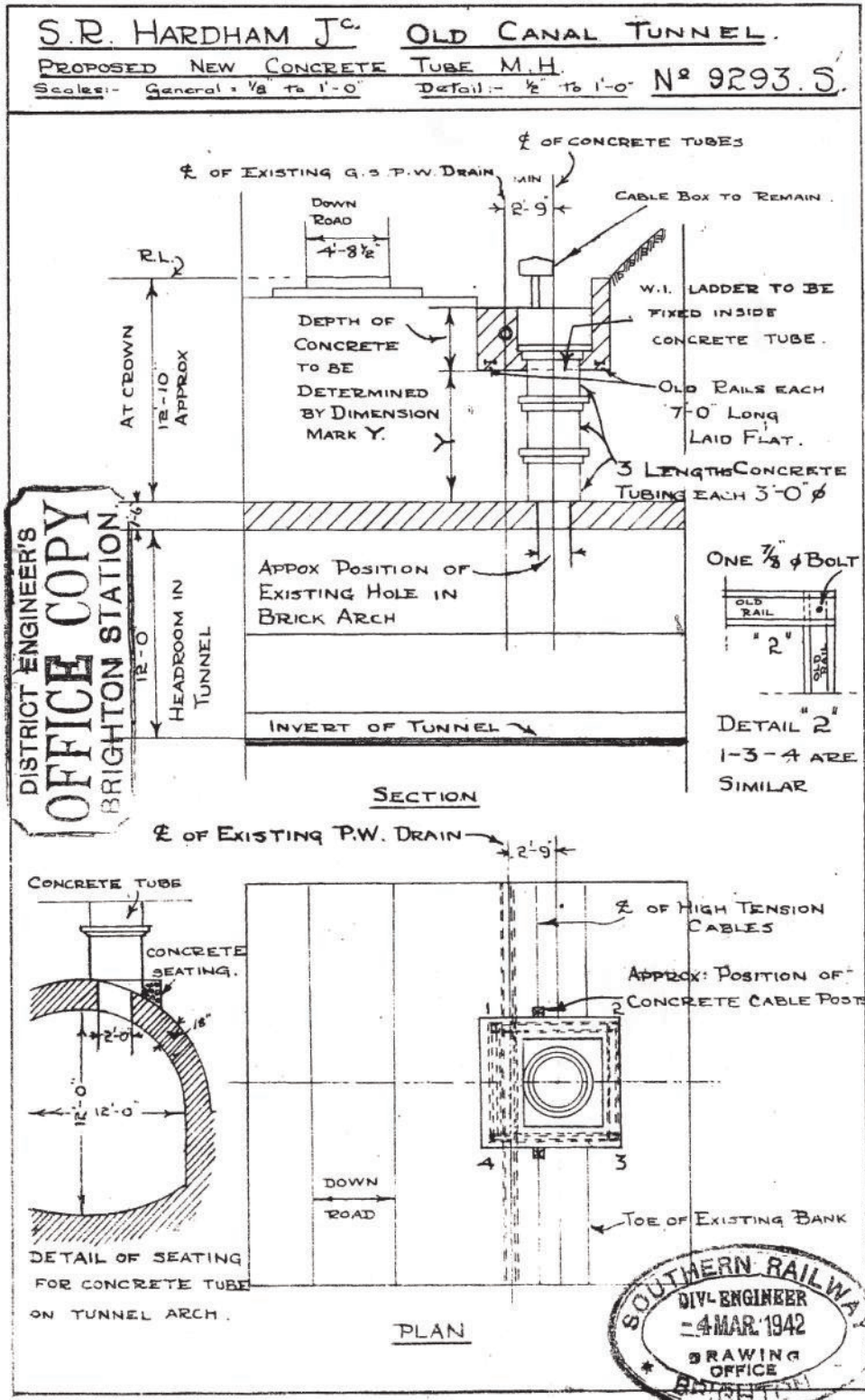

Fig. 17 Southern Railway plan of the proposed new access to the crown of the tunnel,

past the tumbling bay to Fittleworth. In October 1894, a Mr & Mrs Clark from East Molesey boated down from Midhurst en route to Littlehampton, marvelled at the scenery and described their portages past five locks, the floating bridge at Kelsham and shooting over the cill of the upper gate of abandoned Shopham Lock.¹⁸

In 1898 the London, Brighton & South Coast Railway, foreseeing the possibility of subsidence, decided to block up the tunnel at the points where it was crossed by the lines to Arundel and Petworth. This was not a simple operation. First, a shaft several feet in circumference had to be bored a few feet from the main line and carried down to the crown of the tunnel; thereupon tons of chalk and clay were conveyed to the spot in trucks, tipped down the hole and thrown up on either side beneath both lines.¹⁹

In 1948 the North West Sussex Joint Water Board purchased 25 acres of land from the Stopham Estate, including the canal bed from the River Rother to the tunnel, and planned to build a reservoir. This plan failed to materialise. A new waterworks however was built in 1952 by the Southern Water Authority to supply Horsham and Crawley New Town. A concrete dam was built by the north entrance of the tunnel on the site of Tunnel Lock and the channel linking the tunnel to the river used as a filter bed. Three years later the lockkeeper's cottage at Hardham was demolished and the site of Hardham lock and the cut to the river Arun filled in. So too was it felt necessary to obliterate the entrance to Coldwaltham Lock by erecting a flood bank. No signboard commemorates the opening of the Lower Navigation 220 years ago.

The urge to obliterate the vestiges of our transport history serves little purpose. A recent visit revealed that the channel from the Rother to the western end is temporarily inaccessible,

being well protected by barbed wire and thorn bushes. However its location can be discovered by following the public footpath from the former Hardham Water Works. From here the southern end can be reached by crossing the new (2009) accommodation bridge over the railway, traversing the A29 south of Hardham Priory and proceeding along a pathway on the left hand side past a farmhouse, over a stile and down a steepish incline to where clusters of fallen brickwork indicate the tunnel's south entrance. A steel barrier hinders access but the reddish brickwork lining the lichen-covered roof can easily be seen above the glistening shimmer of the water. Here in 1954 the *London Evening Star* reported the author's exploits in paddling a rubber dinghy through the unfenced opening as far as the artificial blockage and the ladder up to the railway track. Of particular note were the stalactites hanging from the roof and the crystal clear water.²⁰

In 2003 the Southern Water Works were decommissioned and today (April 2010) the buildings stand abandoned since office use is apparently precluded by the problem of disposing of the contaminated heavy machinery around which the works were constructed. The filter bed has also been in-filled except for a small pool which is now a wild life haunt bordered by a fine seasonal display of evening primroses. The entrance to the west end



Fig. 18 River Arun Catchment Board barge, 1944. Until the 1950s these barges loaded with chalk blocks were used for bank protection. Similar barge types had regularly used the tunnel loaded with 30 tons or more of chalk for the lime kilns.

of the tunnel is fenced by barbed wire and the steep slope down to the tunnel is difficult to access. However the portal beyond the concrete dam has remained unchanged since viewed fifty years ago. A public footpath leads from the point above the tunnel to the recently rebuilt steel accommodation bridge which crosses the main railway line to Arundel. Beyond this bridge the pathway leads to and crosses the main road, the A272. The approach to the southern entrance is over a stile, down a steep incline. The original facade has collapsed and clusters of fallen brickwork lie amidst the vegetation.

It is curious that so little has been written about the unique tunnel at Hardham, a village whose ancient church and ruined priory have long been noted features. During the Great War George Newnes published Lord Frederick Hamilton's juvenile adventure stories, one of which described an attempt by German terrorists to blow up the Royal Train as it passed over the tunnel.²¹ Some years later Donald Maxwell (1877 - 1936), artist, yachtsman and author of the series of 'Unknown' county books, drew attention in *Unknown Sussex* (1923) to the remains of the 13th century priory and the 'grass grown relics of a defunct canal' but failed to discover the tunnel, although as a boy he had envisaged a voyage by way of the Wey & Arun Canal through a subterranean waterway under the Hog's Back!²² Even more surprising is the fact that in both *A Cruise Across Europe* (1907) and in *Unknown Surrey* he shows his knowledge of the waterway, but omits any reference to it in his later county 'detective' books.²³

One would have expected the uniqueness of the canal tunnel at Hardham, the only tunnel built in the British Isles to link two sections of a river navigation to have been listed as a monument of historic interest. Perhaps this will one day be accomplished so that efforts can be made to preserve and restore both the entrance and the exit.

Notes and References

1. Hadrian Allcroft, *Waters of Arun* (1930), pp66-80.
2. J Fowler (ed.), *The High Stream of Arundel* (1929), pp20-21.
3. No details of this traffic are known, but William Jessop, writing his report on the River Rother in 1783 when it was partially navigable, mentioned that boats below Stopham carried only 15 tons.
4. The five leading shareholders were Daniel and Henry

- Digance, Sir Harry Goring, John Cutfield and Thomas Hampton, each of whom had invested £1,000. Henry Digance was the author of *Thoughts on the Great Advantages Arising from Inland Navigation in General*, Arundel ? 1793, quoted in *Sussex Industrial History 1*, p38.
5. *Sussex Daily News*, 25 January 1790.
6. Section XVIII, Arun Navigation Act 1785.
7. It was reported some months later that part of the tunnel or subterranean arch had given way and collapsed. No-one was hurt nor was there any mention of traffic being halted. (*Sussex Weekly Advertiser*, 27 December 1790.)
8. *Lewes Record*, 13 September 1790.
9. Daniel 5:25-28. These Aramaic words are measures of currency which appeared as the writing on the wall of the king of Babylon's palace. Its meaning as interpreted in the Book of Daniel being a warning of imminent danger.
10. Rev. Arthur Young, *A General View of the Agriculture of the County of Sussex*, 1808.
11. P A L Vine, *London's Lost Route to Midhurst* (1995), p6.
12. Young stated that the cost of the tunnel was £6,000. *ibid* p421.
13. A curious statement, as no tolls were collected on the Rother Navigation until May 1793 when it was opened as far as Fittleworth. (*ibid*, p46.)
14. S E Winbolt relates that Mr A I Clement told Mr Newland Thompkins that his grandfather had built the bridge c.1800 to give access to 27 acres of brook land for hay-making and his cattle. (*Sussex County Magazine* 1927, Vol II p242.)
15. P A L Vine, *London's Lost Route to the Sea*, 5th edition, 1996. Appendix D lists the Arun Navigation Traffic Returns but does not give those of the tunnel.
16. Shown on 25" Ordnance Survey Map of 1876.
17. J B Dashwood, *The Thames to the Solent by Canal and Sea, or the Log of the Una boat 'Caprice'*, 1868.
18. P A L Vine, *London's Lost Route to Midhurst* (1995), pp141-3.19.
19. MS Chief Clerk Engineers' Dept Brig Divisional Engineers; *Sussex County Magazine*, May 1953, Vol 27 No. 5.
20. A similar attempt was reported in the *Sussex County Magazine*, March 1953.
21. The Nine Holiday Adventures of Mr P J Davenant in the year 1915/1916.
22. Donald Maxwell, *Unknown Surrey*, 1924, pp197-205.22.
23. Donald Maxwell, *Detective in Surrey, 1932; A Detective in Sussex*, 1932

SOURCES FOR SUSSEX MILLS, MILLERS AND MILLWRIGHT RESEARCH

Bob Bonnett

Whilst trawling through the Sussex Record Society year books and other archive records for material for a future book on the mills in the Uckfield area, facts were discovered which do not directly relate to Uckfield, but can be of use to others interested in the history of mills in Sussex. I felt it worthwhile, therefore, to list what was found. This is not in any way a definitive list and much, much more can be found in the East and West Sussex Record Offices, the Mill Archive and elsewhere.

Mill-related information in the Manuscripts of the Newnham & Shelley Families, late of Maresfield Park, Maresfield, East Sussex, held by the East Sussex Record Office:

Newnham & Shelley Family Records

Reference No. AB	Date	
170	19 March 1818	Recites Will dated 12 Dec 1814 of William Diplock, late of Fletching, miller, and that he died 14 February 1815.
193 (c)	14 June 1677	Moiety of the forge or iron mill called Little Buxted on the east side or end of said forge as it is now divided by a post standing in the pond bay to the anvil in the hammer block and directly close by the chaffory wheele, in Rotherfeild.
199	2 June 1712	A tenement, barn, garden and lands of 9 acres, near Waldon Mill in Waldron and in the tenure of Samuel Tester.
300	Chas II (1651-2)	4 water corn mills in Kidderminster, Worcs, in tenure of Nicolas Webb.
315	20 March 1625	Leading from Jarvis Brook to Stone Mill.
316		as above
319	25 March 1664	as above
338 (a)	10 Sept 1707	Messuage or tenement and windmill called Argos Hill Mill, on Argos Hill, with stable and two pieces land (heretofore one piece) whereon said windmill is erected, of six acres, in occupation of Thomas Weston, in Mayfield.

This document is of interest as it places the Westons, a very old established milling family in Mayfield, as occupiers of Argos Hill Windmill in 1707. This is over 125 years earlier than previously recorded. (An entry in the Mayfield Parish Register for the 14 June 1584 records the baptism of John, son of Wylliam Weston 'of the Myll'. A later entry of 1587 for the baptism of Debora, William's daughter, refers to 'Cokynghsmill' [Coggings Watermill]).

A mill is shown on Argos Hill on Budgen's undated map issued in 1723. An early reference to a mill in 'Rotherfield' by Miss C. Pulein (revised edition published 1928) says that a 'quit rental' of 1656 proves that there had been, or still was then, a mill on Argos Hill. Later in 1692 Nicholas Puxte of Garden House, Rotherfield held 'Ye windmill field att Argatts Hill'. There are a number of references to the current mill as being built around 1835. Simmons records that Edward Weston, who previously occupied the windmill at Luggers Cross not far away, purchased the land and built the mill. I can find no written evidence of this; however, a new mill may have been built in the 1830s to replace an earlier mill.

I believe that the Weston family occupied a mill on Argos Hill from the beginning of the 18th century for over 200 years. Although Aaron Weston's widow sold the mill before World War 1 to a Mr. Hardy, she was still worked by Raymond Weston, a nephew. Gurney Wilson's notebook records that the mill ceased working in the spring of 1916.

372	4 Aug 1652	Knights Place & Dengate, Rotherfield, 1 iron mill or 'furnace' & workman's houses lately built.
376	24 Nov 1666	Knights Place and the mill and mill house.
377 (g)	23 Sept 1674	Jarvis Brook to Stone Mill.
439 (2)	4 Feb 1878	Geo (George) Heaver, of Buxted, miller.
466	15 Feb 1869 (2)	John Hill, of Maresfield, miller.
468(2)	15 Feb 1869	William Kenward, of Uckfield, miller & Geo Heaver, of Buxted, miller.
858	29 March 1888	Counterpart lease for 21 years at £90 p.a. (2) William Knight, of Shortbridge nr. Uckfield, miller. Water Corn Mill, dwelling house (in 2 tenements) and premises at Shortbridge in Fletching called Shortbridge Mill, with ground, ponds & land of 2 acres adjacent, in occupation of William Knight.
890	3 Nov 1817	Copy Administration of Elizabeth Wood on Death of her husband Jas Wood of Maresfield, miller. Also Water Corn Mill & piece land of 40 rods.
924	8 June 1792	Grant by the Lord by Tenancy to Smith Burley, of Maresfield, miller, Piece land of 40 rods being parcel of the Waste whereon a Water Corn Mill has lately been erected, bounded by lands of Vince Cars on W, by lands of John Newnham, esq. and the Forest of Ashdown on all other parts, and near to the Boring Wheel Pond, in Maresfield.
926	23 Feb 1793	Water Corn Mill & Boring Wheel Pond - Release & Assignment. (1) Smith Burley (2) Samuel Thomas, of Carleton Mews in St. Martin in the Fields, Middlesex, gent. Consideration £400 for same property with messuage or tenement. And premises thereon erected and new use as a Water Corn mill, and the pond by which the said mill is worked, and also the stones, wheels, fludgates, fludhatches, sluices, ressing machine, and other implements belonging.
1028	20 Jan 1692	Woodground of 20 acres near Poundsley Furnace. -_adjacent to lands there called the Old Mill.
1029	4 June 1692	Bond in £2000 for Performance of Covenants for: Quiet Enjoyment, between Charley Caldwell and John Newnham. Recites Surrender of even date by Katherine, wife of Charley Caldwell to Thomas Maedley, gent, steward of the Manor of Framfield, of a messuage called Poundsley; a barn, orchard, gardens, furnace, 2 cornwatermills, and pieces land of New Assert belonging and adjacent, of 62 acres, 3 rods, 2 poles, lying between Poundsley Wood on east and a lane leading from Slewsecrosse to Poundsley Bridge on west, in Framfield and Buxted, late lands of said John Eversfield and now in tenure of said John Newnham and John Cole, to the use and behalf of said John Newnham.
1060	29 Aug 1786	Philip Earl of Hardwicke to secure £16,000, also those Mills & land belonging in Sullington & Storrington which at the time of the above mentioned Lease & Release were in tenure of Richard Bassett at £20. 10s. 6d. p.a.
1072	21/22 Oct 1703	The Fulling Mill Mead of 4 acres in Uckfield.
1074	5 & 6 Apr 1717	The Fulling Mill Mead.
1126	13 Oct 1679	Lease for 3 years at a peppercorn. Thomas Swayne, of Horley, Sy. Yeo, and Elizabeth his wife, to William Hill, of Rusper, gent. Pol Freeheld land called Mill Land, of 80 acres 'rough and playne', in Maresfield, together with 2 messuages and a Corn Mill, in tenure of Adrian Duffield and Hen Bryant.
1292	14 Mar 1726	Presentation of Death of Wil (William?) Wood, & Adm of Thomas Manser, his 'nearest kinsman' & son of Tho Manser, late of Wingham, Kent, miller, deceased. Barn & 1½ ac land at Poundgate in Buxted.
1337	23 Oct 1688	Leading to a pond called Boring Wheel Pond.
1502	28 June 1826	Release & Conveyance. Wil Grey, Sir John Shelley & Jas Stephen Wickens. Also messuage or tenement, mill & farm called Poundsley Mill & Farm with land of approx 78 acres in Framfield.

Another small, but interesting area of research material is in the records of coroner inquests as there are records dating from the middle ages. The information below is from the S. R. S. volume 77.

Coroner Inquests

Coultershaw Mill—3 March 1537. Petworth. Philip Cooper, county coroner.

Between 3 and 4 a.m. on 23 Jan John Levys late of Petworth, 'capper', went from his house at Petworth to a stream running from Coultershaw Mill southwards to Wide Mead and 'Meryfeld' and feloniously drowned himself in 8 feet of water there. He had goods and chattels worth 13s. 4d. which are deodand and remain with his relict Ellen for the King's use.

K.B. 9/537, m.53.

Horsemill—John Knott, miller 29 Jan. 1554 Chichester. Richard Knight, Chichester city coroner.

At 2 p.m. on 29 Jan. Amy Lewes, aged 13, servant of John Castilman of Chichester, wandered idly in the city, came to ‘a horsemill’ belonging to John Knott of Chichester, then a miller, and went so carelessly within the sweep of the mill’s arms, which were being turned by horses, that one of the arms struck her on the right side and killed her.

KB 9/587, m.221.

Runton— Runton Watermill, John Morye, miller. 24 Aug 1554.

Runton in North Mundham. Nicholas Lewkenor, county coroner.

About 7 p.m. on 22 Aug. John Combes of Runton went from his house at Runton to the stream of a watermill to fetch ‘a cowueltubbe’ [*sc.* a cowl-tub, a tub for water] from John Stamforde’s wife, which his own wife had previously lent her, and also to get John Stamforde’s servant or maidservant to carry his linen clothes called ‘le buckenge clothis’ [*sc.* bucking clothes, clothes which had been bleached] to his house. When Combes had got to the King’s highway about an acre’s width from the watermill, John Morye of Runton, ‘miller’, came out of the mill and struck him on ‘le nappe of the hed’ with ‘a plant hasell staffe’ which he held in both hands, so that he fell wounded to the ground. When he recovered, he set off for his house and got to ‘Downer’s mede’, the width of 2 acres from the King’s highway, where Morye pursued him to a hedge and murdered him with a dagger worth 2s. which he held in his right hand, giving him a wound on the left side of the chest to the heart of which he immediately died. Morye immediately returned to the watermill, where his brother Nicholas was, and said to him: I think I have killed him; and they both immediately fled together. The jurors do not know if Nicholas was guilty of or consented to the murder. John Morye had chattels seized by George Bachelor, the earl of Arundel’s bailiff of Arundel rape, as appears etc. [*sic*]

KB 9/587, m. 236

[John Morye was outlawed at Lewes on 31 May 1555, although there is a note on the inquest that he had been hanged at Chichester on ‘Wednesday last’. The coroner was summoned to King’s Bench to answer for defects in the inquest; in Easter 1556 he fined 13s. 4d. and found sureties.]

A Land Tax was introduced in 1692 and not abolished until 1963. From 1776 it was levied at 4s 0d in the pound. The list below is taken from the S. R. S. volumes 77 and 82. Tax assessments survive in their fullest form from 1780 to 1832 and are a valuable source to find the owner and occupier of a property. As anyone who has researched mills knows, it is difficult to ascertain who is the owner, tenant or miller before the full censuses were taken. Using the lists below as a starting point, tax assessments for earlier or later years can be found, or related records such as title deeds or rate lists, to help trace a mill’s history.

It must be noted that not all towns and parishes gave a description of the property, therefore not all mills are listed. Mill fields, mill woods etc. are also listed in the books and can be used to determine where a mill may have stood; they are not included here.

Mills Recorded in the East Sussex Land Tax

Parish	Owner	Occupiers	Lands	Rental £
Alfriston	Ade, John	himself	mill	2
Ardingly	Hamlin, Miss Mary Hollands, John	Harmer, Henry himself	fulling mill his mill & land	8-10 5
Balcombe	Wakeham, Thomas	Booker, John	mill	8
Battle	Pepeer, James	himself	Battle Mill	3
Beddingham	Jarvis, Edward	himself	his mill	5-10
Bexhill	Stace, John	himself	land & mill	5
Bishopstone	Woods	himself	his mill	50
Brede	Holman, John (heirs of)		the powder mills	20
Brighton	Dennett, Mr. Bradford, William Brown, John	Sickelmore himself himself	wind mill wind mill wind mill	1-10 3 1-10
Burwash	Hilder, Edward Pelham, Rt Hon	himself Skinner, John	Dadwell Mill Park Mill	17 12
Buxted	Wildish, James	Uridge, John	Tibs Mill	4

Chailey	Hoather, Thomas	himself	the mill	1
Chiddingly	Bromfield, John Willard, Joseph	Gurr, Richard	mill	8
		himself	mill	4
Clayton	Rickman, Mr.	Gadly, John	mill	15
Crowhurst	(Not listed)	Hammond, Mrs.	the mills	31
Cuckfield	Sergison, Francis Kennard, Thomas	himself	Cuckfield Mill	30
		himself	his two mills & farm	20
Ewhurst	Richardson, John	himself	two mills	5
Falmer	Christmas, Richard	himself	mill	4-4
Fletching	Sheffield, Lord Childs, Robert Wilson, Sir Thomas Weston, Henry	Austin, Mr.	Sheffield Mill & farm	27
		himself	mills	7
		Peckham, George	a house, land & mill	4
		himself	the mill & land	14
Frant	Abergavenny, Earl Pratt, John Ashby, Thomas	Fry, John	Eridge Mill	12
		himself	Bayham Mill	13
		himself	Bartley Mill	9
Hastings	Millwards, Edward Carswell, Joseph English, John Foster, Thomas	himself	watermill	5
		Carswell, Joseph	his mill & land	3
		himself	his mill & land	5
		himself	his mill & land	3
(Winchelsea)	Clark, Mr.	himself	his mill	4
Heathfield	Fuller, John	Dan, Jasper	mill, late Holman's	8
Hellingly	Earle, Henry Kennard, John	himself	his mill	8
		Kennard, John	his mill	7
West Hoathly				
(Selsfield)	Young, John	himself	his house & mill	8-10
Horsted Keynes	Hamden, Lord Saxby, Mr. sr	Rose, Edward	the mill & mill land	13
		Parker, Francis	old forge & old mill	7
Hurstpierpoint	Avery, Nathaniel Avery, Nathaniel Wickham, Henry	himself	mill & land	20
		Lindfield, William	Cobs Mill	7
		Peskett, William	the mill	8
Isfield	Radcliffe, Sir	Cripps. J	Old Mill	24-10
Keymer	Hassell, Mr. Welfare, Thomas Barton, Thomas	Haynes, John	fulling mills	6
		Welfare, William	the mill	3
		himself	his mill	6-10
Lewes	Kennard, John	himself	his mill	6
Lindfield	Barham, Nathaniel Wyatt, Richard Powell, Jenny	himself	Newhouse & Mill	2-5
		Harland, Anthony	Cockease Mill	5-10
		Martin, George	Fulling Mill,	28-15
South Malling	Hother, Charles	himself	mill	10
Maresfield	Holford, P. Hamlin, Francis	Wood, William	Old Land Mill	8
		Morfey, William	Nutley Mill	12
Mayfield	Kirby Mr. Tompsett, John	Damper & Stapley	old mill	39
		Austin, Edward	Old Mill	7
Northiam	Day, David	himself	the mill	1
Pevensey				
(Westham)	Gorringe, W. P.	himself	windmill	4
Poynings	Montague, Lord	Souch, James	mill & land	15
Rottingdean	Richardson, William	Richardson, William	mill	2-10
Rye	Clark, Robert	himself	his mill	6
Salehurst	Hilder, John	himself	the water mill	40

Seaford	-	Bull, Richard	Washers Mill	13
Slaugham	Sergison, Frances Budd, Frances	Heaver, Mrs.	the mill	6
		Tulley, John	the windmill	2
Ticehurst	Newington, Joseph	himself, miller	the mill	10
Udimore	Sloman, George	Sloman, George	mill	4
Wadhurst	Legas, John Ashby, Thomas	Rowland, John	Riverhall Mill	9
		Ashby, Thomas	part Bartly Mill	1
Waldron	Fuller, John Saunders, Thomas	Bonnick, John	the mills	8-6-8
		himself	mill	4-10
Warbleton	Reeves, John Bristed, James	Reeves, John	mill & land	17
		Saunders, John	Crawle Mill & Land	12
Wartling	Collins, Stanton	himself	mill & c	30-10
Withyham	Dorsett, Duke of	Curry, William	the mill	11
Worth	Sergison, Frances Blunt, Samuel Evelyn, James Evelyn, James Rice, John	Tester, Richard	Tilgate Forest Mill & pond	135
		Tidy, William	Haselwick Mill	29
		Look, John	the windmill	5
		Look, John	the Furnace mill	5
		himself	the windmill	3

Mills Recorded in the West Sussex Land Tax

Parish	Owner	Occupiers	Lands	Rental £
Arundel	Norfolk, Duke of Norfolk, Duke of Carlton, Edward	Norfolk, Duke	--& Mill Hanger	19
		Horn, John	watermill	40
		Overington, Henry	Great windmill	2
Ashington	Harwood, Thomas	himself	mill	4
Barlavington	Biddulph, John	Iddetson, Mr.	house where mill stood	2
Upper Beeding	Slaughter, Harry	himself	his windmill	5
Bignor	Newburdge, Earl of	Tipper, George	mill	16
Birdham	Reeves, Mr. Ayles, Mr. Mountifield, John	himself	watermill	13
		himself	watermill	13
		himself	windmill	7
Bosham	Williams, P Williams, P Pannell, John	Diggens, Francis	Bosham Mill	66
		Woods, William	Broad Bridge Mill	34
		Pannell, John	Salt Mill	15
Burton	Biddulph, John	Lindfield, Messrs.	Burton Mill, etc.	13
Climping	Challen, William	Hammon, John	his mill	2
Cocking	Montague, Lord	Ellis, Benjamin	the mill	28
Cowfold	Souch, James	Terrell, Richard	Gostdean House & mill	6
Durrington	Shepard, William	himself	his mill	5
Easebourne	Montague, Lord	Tipper, William	mill	32
Fittleworth	Turner, John	himself	his corn mill	20
Funtington	Cresswell, John	himself	house, mill, etc.	42
(West Ashling)	Coote, John	himself	house & mill	33
Harting	Lake, John Fetherston [haugh] Stawell, Lord	Eldridge, James	land & mills	13
		Hall, John	Hurst Mill	9
		Walton, William	Part of Durford Mill land	4
Heene	Clough, Richard	Parker, Mrs.	his mill	6
Henfield	Dunstall, widow	Patington, Richard	The windmill	3
Horsham [Southwater]	Tredcroft, Nathaniel	Wood, William	mill & Laggs	18

Iping	Egremont, Lord	Bigg, John	paper mills	14
Kirdford	Haines, Gregory Winterton, Earl of	Ford, James Dale, Edward	mill Park Mill	3 19
Lancing	Biddulph, Charles	Oliver, John	mill	6
East Lavant	Cleverly, William	Tipper, Thomas	Hays Down Windmill	1
Linchmere	Fielder, Ann	Simmons, William	Shottermill	20
Littlehampton	Shepherd, Ayling	owner	mill	3
Lurgashall	Montague, Lord	Baigent, Mrs.	Lurgashall Mill	2
[Diddlesfold]	Leech, John	himself	mill & dale	5
Midhurst	Montague, Lord	Amber, Richard	millpond & plot	9
North Mundham				
[Runkton]	Brewer, Mr.	-	mills & land	12
Oving	Knott, Mrs.	herself	windmill	1
Pagham	Adhames, Mr.	Brewer, John	land & mill	8
Petworth	Egremont, Earl of	Dale, Mr.	corn mill	35
Pulborough	Frogdean, Mr. Greenfield, Michael	Hammond, Charles Greenfield, Michael	Nutbourn Mills Heath Mill	13 10
Rogate	Stowell, Lord	Walton, William	Durford Mill	13
Rudgwick	Killick, John	himself	windmill & house	5
Rustington	Drewatt, Miss	Nolson, Mrs.	mill	6
Selsey	Reeves, William	himself	land & mill	15
Shermanbury	Challen, John	Ede, William	mill	12
Old Shoreham	Newnum, James	himself	mill & land	20
Sidlesham	Kingsford, Mr.	himself	mill	84
Southwick	Burton, John	himself	mill	1
Stedham	Peachey, Sir James	Eldridge, Mrs.	watermill	14
Steyning	Comber, Richard Markwick, William	Comber, Benjamin himself	mill his mill	10 8
Storrington	Lidbetter, John Ashburnham, Rt Rev	himself Baker, Henry	mills & land mill & land	20 20
Trotton	Lintott, Thomas	himself	Ligate Mill	14
Westbourne	Barwell, Richard Barwell, Richard	Cathrey, Richard Goodman, Joseph	mill & meadows Bourne Mill	35 6
[Aldsworth]	Painter, Mr.	Tribe, John	mill	7
[Nutbourne]	Mant, Mr.	Wright, Mr.	mill	20
[Prinstead]	Hartfield, Mr.	himself	mill	3
[Prinstead]	Barwell, Richard	Hendy, Mr.	mill	15
Westhampnett	Knott, William	Knott, Mrs.	mill & field	8
Wisborough Green	Seward, Miss.	Steward, Thomas	watermill (Brewhurst?)	5
Wiston	Wells, Philip	Drewett, Richard	Rush Mill	6
Woolavington	Mounteygue, Lord	Eldridge, John	mill & plats	10

Mill-related Information can be found in the East Sussex Parliamentary Deposit Plans recorded from 1799-1970 by Roger Davey in the Sussex Record Society Volume 78. The plans not only show the location of the mill, but many have a reference book or table detailing the owner and occupier.

Parliamentary Deposit Plans

ESRO Ref.	Plans
QDP 2	Sea Water Aqueduct from Brighton to Kennington, 1799. (Shows --- windmills at Patcham, Clayton and Keymer.)
QDP 13	Turnpike Road from Pyecombe to Staplefield Common, 1807. (Shows --- small drawings of a windmill at Hurstpierpoint and a windmill at Bolney. A table on the plan gives owners and occupiers.)
QDP 29B/1	Newhaven Harbour, 1810. Plan of the harbour of Newhaven. (Small drawing in elevation of the Tidemill.)
QDP 49	River Cuckmere Navigation, 1813. (Small drawing of Horsebridge Mill and names Michelham Mill. Book of reference gives landowners and occupiers.)
QDP 50	Canal from River Rother Navigation to Mayfield, 1813 (Shows --- Names Oakham Mill, Bugsell Mill, Witherden Mill, Parsons Mill Stream and Moat Mill. Book of reference gives landowners and occupiers.)
QDP 66	Turnpike Road from Hickstead to Warninglid and Handcross, etc., 1818. (Attractive small drawing of Bolney Windmill. Book of reference gives landowners and occupiers.)
QDP 89	Turnpike Road from Brighton to Cuckfield and Handcross, etc., 1824. (Small drawings of windmills on Bolney Common, Whiteman's Green and St. John's Common. Book of reference gives landowners and occupiers.)
QDP 93	Canal from Lewes to Brighton, 1825. (Small drawing of a windmill at Brighton. Book of reference gives landowners and occupiers.)
QDP 94	Turnpike Road from Newhaven to Eastbourne, 1825. (Drawings of windmills at Friston and Seaford. Book of reference gives landowners and occupiers.)
QDP 99	Turnpike Road from Hickstead and Warninglid Cross to Handcross (New Line), 1825. (Small drawing of a windmill on Bolney Common. Book of reference and table on plan gives landowners and occupiers.)
QDP 204	South Eastern Railway, from Tonbridge to Hastings and Rye, 1844. (Shows windmill at Frant and powder mill at Battle. Separate plan shows powder mill at Sedlescombe. Book of reference plan gives landowners and occupiers.)
QDP 218	Newhaven and Seaford Branch Railway, 1845. (Outline plans show the Tide Mill, Mill Pond and Tide Mill Creek. Book of reference gives landowners and occupiers.)
QDP 231	South Eastern Railway (9), 1845: Tunbridge Wells, Rye and Hastings Railway. (Shows windmills at Frant and Battle, Bugs Hill Mill and a powder mill at Battle. Book of reference gives landowners and occupiers.)
QDP 295	Newhaven and Seaford Railway, 1860. (Shows the Tide Mill and Tide Mill Creek. Book of reference gives landowners and occupiers.)
QDP 300	London, Brighton and South Coast Railway, 1861. (Names the Tide Mill. Book of reference gives landowners and occupiers.)
QDP 303	East Grinstead, Groombridge and Tunbridge Wells Railway, 1861. (A mill is shown at East Grinstead and a tan yard at Withyham. Book of reference gives landowners and occupiers.)
QDP 314a	Newhaven Harbour and Docks, 1862. (Plan names Mr. Catt's Tide Mill. Book of reference gives landowners and occupiers.)
QDP 355	Newhaven Harbour and Docks, 1865. (Plan names Tide Mill. Book of reference gives landowners and occupiers.)
QDP 432	Newhaven Harbour and Docks, 1877. (Plan shows Tide Mill and diversions of Mill Creek. Book of reference gives landowners and occupiers.)
QDP 460	Newhaven Harbour and Docks, 1881. (Plan names Tide Mill. Book of reference gives landowners and occupiers.)
QDP 589	Newhaven Harbour Sea Wall, 1897. (Plan names Tide Mill. Book of reference gives landowners and occupiers.)

Perhaps not as fruitful for research purposes but interesting to read are old court records where millers and millwright appear to be, like the rest of the populace, not immune to a little 'how is your father'. The lists below are taken from Volume 83 of the Sussex Record Society.

Mid Sussex Poor Law Records

Sussex Millers and Millwrights (West Sussex Record Office)

- Cuckfield** 1739 April 13. John Tooth, eldest son of John Tooth of Ardingly, yeoman apprenticed to Michael Godsmarke of Cuckfield, millwright, for seven years; trade of millwright. Consideration £7, paid by John Tooth the elder. East Grinstead 1754 June 24. Mary Edwards, singlewoman, said that she is now quick with child, and that Robert Knight of East Grinstead, miller, is the father of her child.
- East Grinstead** 1786 August 14. Sarah Gibb of East Grinstead, singlewoman, has declared that she was delivered of a female bastard child on 21 July last at Dean Farm House, East Grinstead, and that George Wood, late servant to David Jenner of East Grinstead, miller, is the father; and George is to be apprehended.
- East Grinstead** 1787 December 26. Thomas Brooker at Worth said that two and a half years ago he hired himself to Mr Edward Jenner of East Grinstead, miller.
- East Grinstead** 1810 September 14. Mary Hooker of East Grinstead, singlewoman, has declared that she is with child and that William Brigden, miller, late of East Grinstead, is the father; and that he is to be apprehended.
- East Grinstead** 1821 May 3. At Worth Ann Brooker, singlewoman, was delivered of a male bastard child on 12 January last, at the house of Thomas Stone of Worth. Jonathan Rice of East Grinstead, miller, the father of the child, to pay £1 19s 6d towards the expenses of birth, 13s 0d for the cost of obtaining order, and 2s 6d per week; the mother to pay 6d a week.
- Henfield** 1600 October 3. William Cook, aged 8 years, son of Will Cook, apprenticed to Edward Sewer of Henfield, miller, until age 24 years; husbandry. Consideration of £5 paid by the parish offices, 50s 0d at (unknown) and 50s 0d at Easter following, paying nothing to the poor in six years following, unless he comes in greater occupying.
- Henfield** 1658 October 22. Richard Roffe, aged 8 years, apprenticed to John Gardner of Henfield, miller, until age 24 years.
- Hurstpierpoint** 1800 November 22. Edmund Buckwell said that 17 years ago he removed his wife and three children from Fletching to Hurstpierpoint, and hired himself to William Lindfield of Hurstpierpoint, miller, at wages of half a guinea per week. Eleven years later he quitted the services of William Lindfield as a miller but worked as a labourer.
- Lindfield** 1735 March 18. Mary Vinall, singlewoman, has declared that John Comber of Lindfield, miller, is the father of a male bastard child born to her in Lindfield. John Comber to pay 1s 6d per week maintenance and £1 5s 0d already expended since the birth; the mother to pay 6d per week.
- Slaugham** 1801 March 7. John Sayers hired himself to William Heaver of Slaugham, miller, for half a year at wages of 5 guineas, then hired again for half a year at wages of 4 guineas, after which he lived with William Heaver for two and a half years more without making any fresh agreement.

Surrey Millers and Millwrights (Surrey History Centre, Woking)

- Fetcham** 1806 November 20. At Worth Edward Ellis, of Fetcham, Surrey, miller, bound to the parish officers of Worth in £200 in respect of Mary Humphrey of Worth, singlewoman, who has declared that she is now with child and that Edward Ellis is the father. (It is interesting to note the huge bond over sum of £200 which must have reflected the success of his mill)
- Godstone** 1714 May 17. Lindfield. George Belchamber apprenticed to Thomas Heath of Godstone, Surrey, carpenter, until age of 24 years; "art, trade or manual occupation of a carpenter, millwright and pumpborer".
- Godstone** 1805 February 22. John Rice of Worth, miller, said that he believes that he was born in Worth. That when he was 14 or 15 years of age, he went into service of his relation, John Lock of Godstone, Surrey, miller. (This was around 1780)
- Lingfield** 1744 July 9. Joseph Galyon of the 2nd Regiment of Foot said, that about 12 years ago, he hired himself as a yearly servant to John Bower of Lingfield, Surrey, miller and millwright, at wages of £7 10s 0d for the space of a year.



Gossops Green windmill, Crawley
Lithograph c.1845

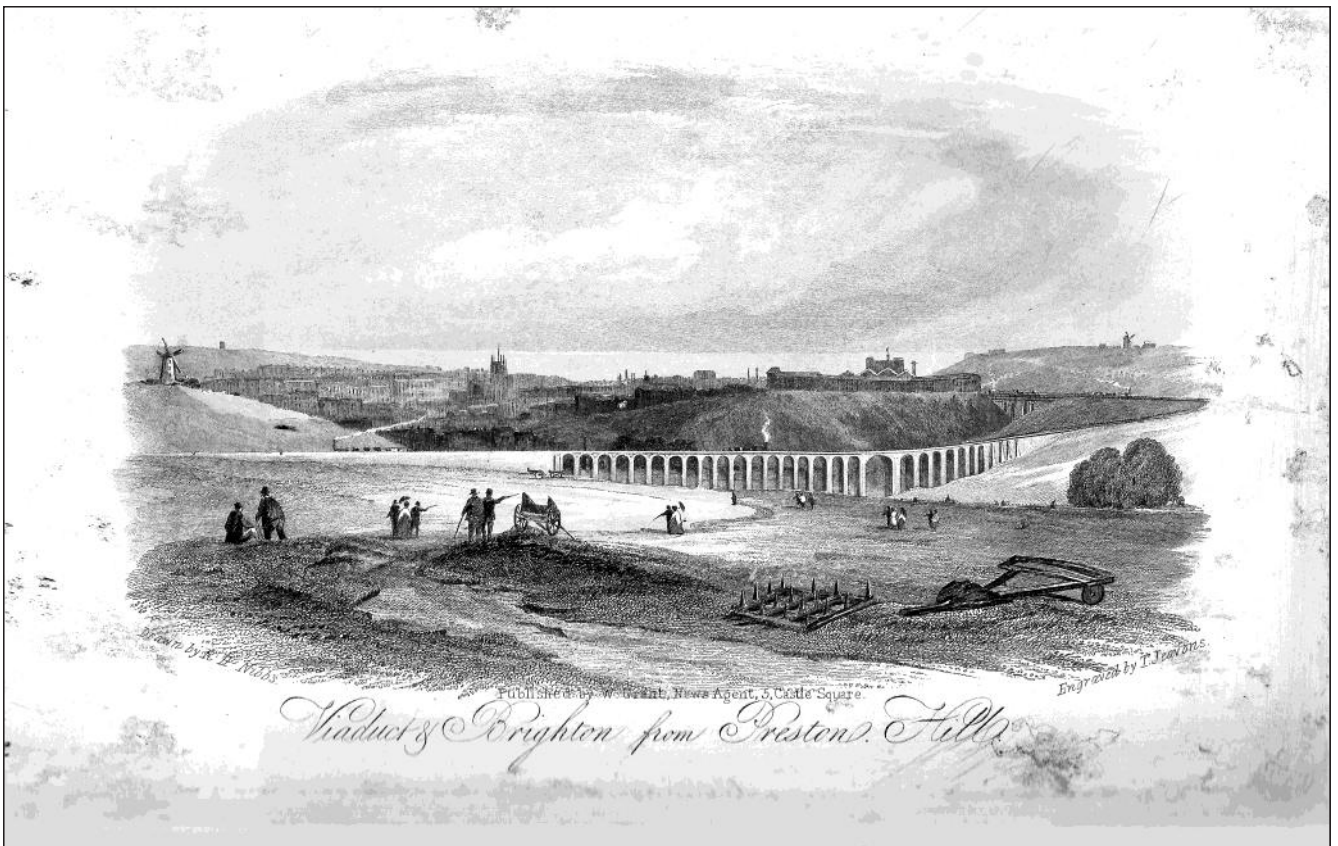

Viaduct over Preston Road, Brighton, also showing two of Brighton's windmills.
Steel engraving c.1850.

THE CANAL PUMPING STATION AT FORD

Alan H. J. Green

Introduction

The Portsmouth and Arundel Navigation (P&AN) was promoted to complete an inland waterway route from London to Portsmouth and authorised by Act of Parliament on 7 July 1817.¹ The project included the construction of a canal from the River Arun at Ford to Chichester Harbour at Birdham, a distance of nearly 12 miles, which, together with a short branch to Chichester, formed its Sussex Line. The Engineer appointed for the project was the great John Rennie, then aged 56.

For the entrance to the canal at Ford, Rennie designed two locks to handle the rise from the River Arun and specified a pumping station ('engine') to raise water from the river to feed the Sussex Line. The ensemble was completed by a pair of semi-detached cottages to house the engine and lock keepers.

Although the troublesome construction of the well for the pumping station, and its subsequent redundancy, is recorded in the Canal Company's annual reports, until recently we knew very little else about it. It somehow managed to escape the attentions of photographers (no such image has yet surfaced) so we had only a few artists' impressions to tell us what it looked like, and what was inside was also a mystery. It had long been the assumption that the equipment was supplied by Boulton & Watt, firstly because they had virtually cornered the market in steam pumps at this time,



Fig. 1 A painting, dated 1888, of the top (No. 2) lock at Ford, with the pumping station in the background, one of the few images we have of this significant engineering feature of the Portsmouth & Arundel Navigation. At this time the canal had long-been disused; the lack of water and the derelict state of the lock gates will noted. (WSRO)

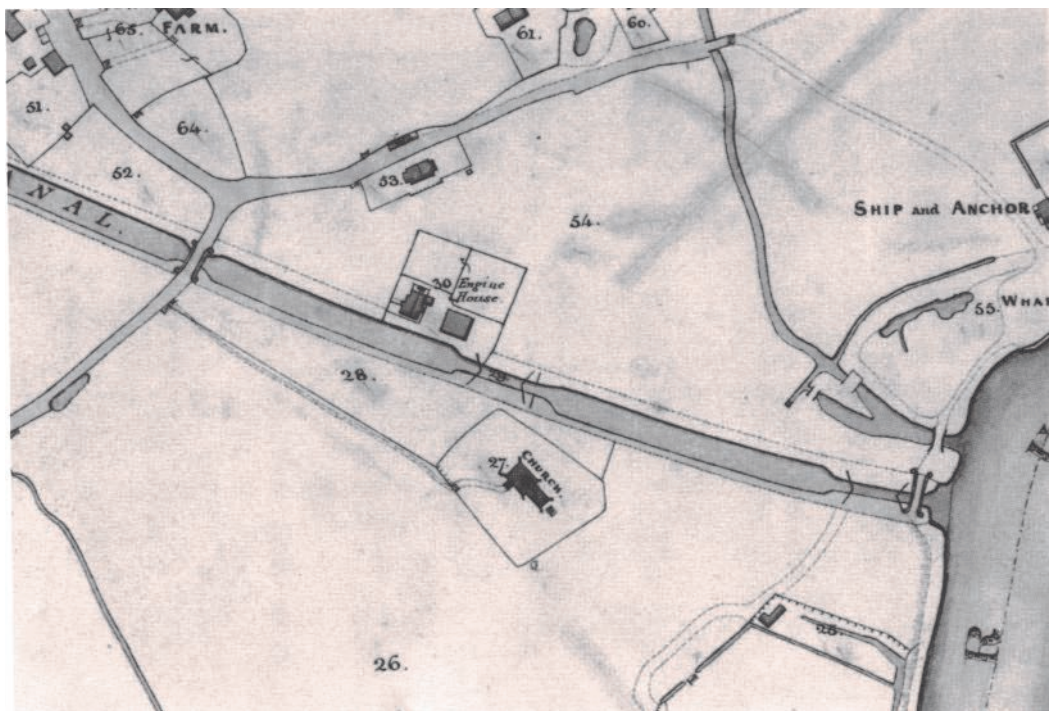

Fig. 2 An extract from the Ford tithe map of 1839 showing the locks, the pumping station (indicated as 'engine house') and the two cottages for the lock and engine keepers. (WSRO)

and secondly on account of Rennie's previous association with that company - but we had no proof. All that changed however in 2008 as a result of investigations by the SIAS Canal Group.

The investigations began when Chris Bryan became aware of the Boulton and Watt Archive at Birmingham City Library via an article he had read in the transactions of the Newcomen Society. This raised the question as to whether the said archive might contain any material relating to the P&AN, so Aage Roberts made enquiries and duly ventured north to investigate. What he found was immensely exciting; not only did the archive contain the detailed drawings of Ford pumping station, and its sister installation at Milton on the Portsea Line, it also held the order books and correspondence between John Rennie and James Watt.

He brought back copies and I spent a long and fascinating time analysing them. The Birmingham discovery was made just in time for me to include a synopsis of the new information, and an extract from one of the drawings of Ford pumping station, in the third edition of my *History of Chichester's Canal* upon which I was then working.² Unfortunately the small format of the book did not permit sufficient space for me to do the subject full justice, but *Sussex Industrial History* provides a larger canvas upon which to work, allowing for some of the Boulton & Watt drawings to be reproduced in their entirety, and for me to combine this new information with my previous researches to give a detailed account of the pumping station at Ford.

Matthew Boulton, James Watt and the Soho Manufactory



Fig. 3 Matthew Boulton (1728-1809) portrayed in a lead medallion. It is signed *J Smith* on the socle.
(Author's collection)

Matthew Boulton, one of the greatest figures of the Industrial Revolution, was born in 1728 to a Birmingham button maker. He was possessed of a brain the size of his home town, showed great creative and entrepreneurial skills and was the leading figure in the Enlightenment movement. In 1762 he set up his famous Manufactory at Soho on the outskirts of Birmingham, which he described as *A Temple of Vulcanic Arts*. He began, in partnership with the silversmith John Fothergill, by manufacturing Sheffield plate, silverware and elaborate decorative objects in ormolu-mounted Derbyshire Blue John, all of which were of very high quality. His intention was to equal or better the quality of London manufacturers and in this he was successful, receiving several commissions from King George III, that undoubted connoisseur of fine *objects d'art*. So successful was the Soho Manufactory that Boulton quickly branched out into other fields including the minting of coins.

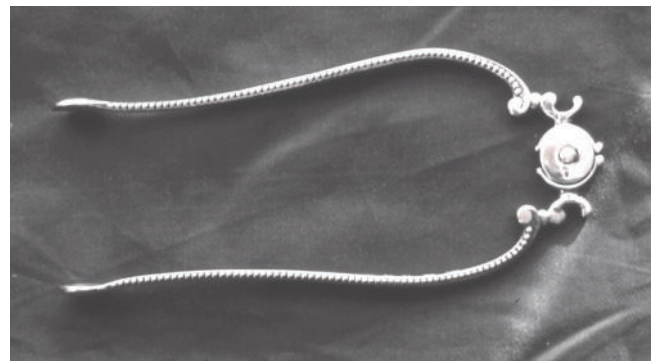

Fig. 4 A pair of silver sugar tongs made by Matthew Boulton and John Fothergill, hallmarked 1776. Typical of the sophisticated output of the Soho Manufactory these tongs, instead of being made from a single sprung strip of silver in the usual way for the time, consist of two separate arms with a steel spring in a central pivot.
(Author's collection)

The Scottish engineer James Watt stayed with Matthew Boulton at Soho in 1768, and in 1775 the two men entered into partnership as *Boulton & Watt* to start manufacturing steam pumping equipment for mines and canals, and rotative engines for factories. In this venture Matthew Boulton again set out to better what was currently on offer, and so successful was it that in 1796 a separate Soho Foundry was opened a mile away on the banks of the Birmingham Canal. By 1800 no fewer than 500 Boulton & Watt steam engines and pumps were in use.³ After Matthew Boulton's death in 1809 the business was continued by his eldest son, also called Matthew.

In 1784 James Watt received a visit at Soho from a promising young engineer named John Rennie, with whom he was so taken that he awarded him his first major post, a seven-year contract to supervise the installation of Boulton & Watt engines and pumps.⁴ As such the future Engineer for the P&AN was well acquainted with the products and capability of Messrs Boulton & Watt, so it should come as no great surprise that he would approach them about the design and supply of the pumping installations for Ford and Portsea.

The order is placed

From July 1818 The peripatetic John Rennie was in regular correspondence with the equally peripatetic James Watt about the project. Rennie placed the order for the two engines by letter to Watt, on 10 July 1818, 'putting both engines into your hands,' and the following day he wrote another letter to a Mr Creighton, presumably a manager at Soho, as follows:⁵

London July 11th. 1818

Dear Sir

I have sent an order to Mr. Watt for the two steam engines for Portsmouth* - but I suppose he is from home - I believe gone in the Caledonia as I have heard nothing from him - the plans of the Building for the larger of the two Engines is wanted to be at Portsmouth by the 21st that they may contract for the building - I therefore write you that you may be preparing them without loss of time - you may fit the boiler where it best suits you as there is no other building near it.

I am, Dear Sir
Your Most Humble
John Rennie [signed]

Mr. Creighton

Soho

* This means the two engines for the P&AN - i.e. one at Ford and one at Portsea - not that there were two engines at Portsmouth *per se*. The engine at Ford was, at that time, to be the larger of the two. The Canal Company's offices were at Portsmouth hence the requirement for the drawings to be sent thither.

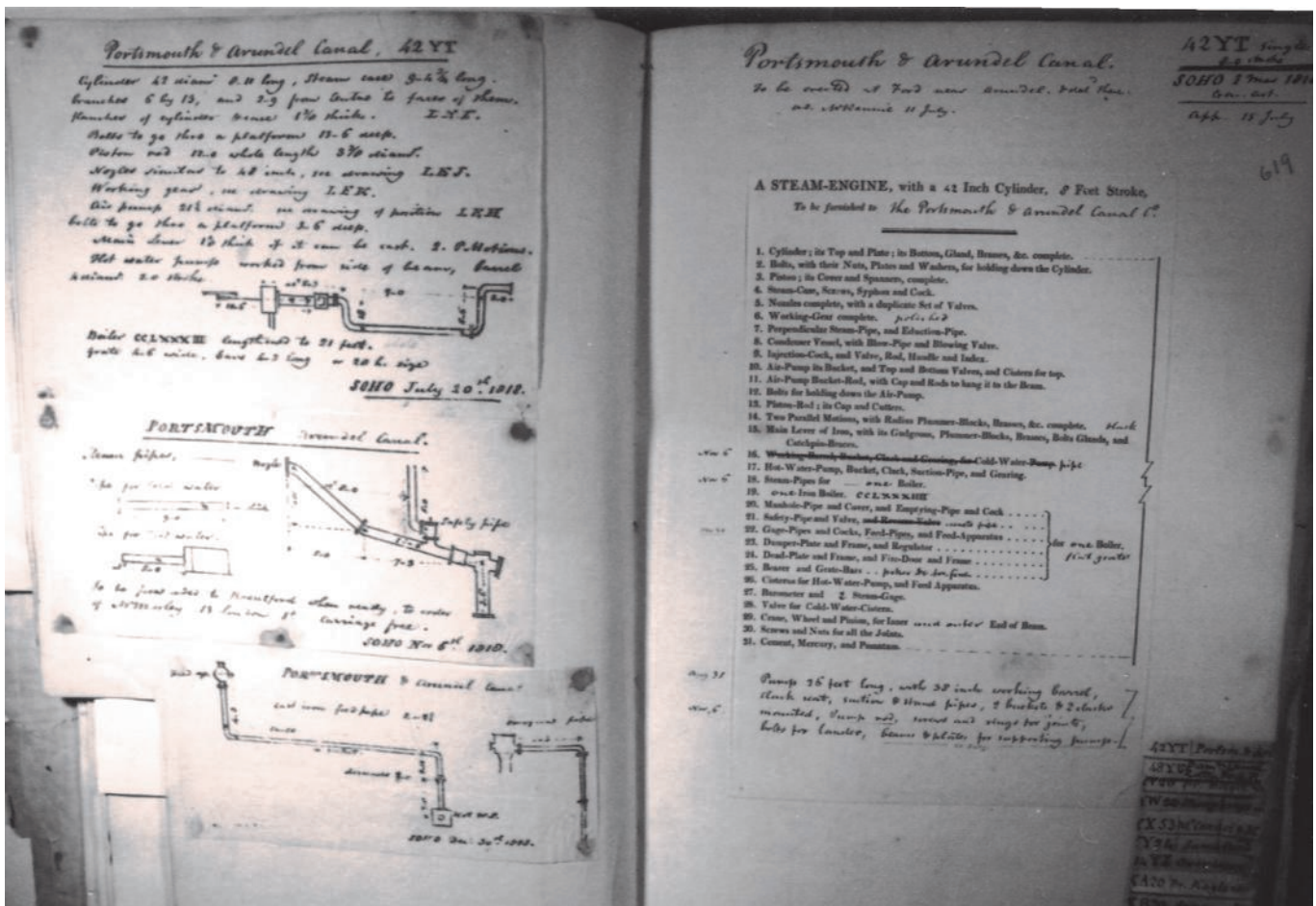

Fig. 5 An extract from the Boulton & Watt order book for the Ford engine. The left-hand page gives site-specific details of pipework and on the right hand page is a summary of the order entered into a standard pro-forma. '42XT' is the order number for the P&AN installations. (Reproduced with the kind permission of Birmingham Libraries and Archives)

The working drawings duly followed with amazing rapidity for the first are dated 15 and 18 July and the last 31 August 1818. The reason for this celerity was that Boulton & Watt had introduced standardisation of components for both the engines and the pumps, so it was simply a case of picking and mixing to suit the requirements of the order. Similarly they used printed pro-forma order books requiring only the quantities and prices to be entered alongside the applicable standard components, with non-standard details being added by hand on adjacent blank pages. The estimated cost of building and equipping the pumping station at Ford was reported by Rennie as being £2,760.⁶ As the above letter demonstrates, the building to house the engine and pump was also designed by Boulton & Watt.

The drawings in the Birmingham archive are all marked 'reverse' even though the lettering thereon is the right way around. The reason for this, and also the speed with which the drawings were able to be issued, lay in Watt's invention of a copying machine which he patented in 1780. Letters and drawings were prepared using slow-drying ink, and when finished a sheet of moist paper was placed on top. The original and paper were then passed through rollers and the paper thus gained an impression of the original - but in reverse.⁷ Letters would be copied onto tissue paper and could be read by the simple expedient of turning the copy over, but for drawings a more durable medium was required so translucent tissue paper was not practicable. Instead a layout of standard components was produced and copied by the machine onto cartridge paper, then the lettering was added to the prints. So successful were these machines they were manufactured at Soho for sale - the world's first successful copying process. One was exhibited at the superb exhibition at Birmingham Museum and Art Gallery, staged in 2009 to mark the bicentenary of Matthew Boulton's death, and one has even turned up on *The Antiques Roadshow*.

The pumping station at Ford

As the river was tidal at Ford, and the canal entered the sea at its other end, Section LVI of the Act made a very specific provision to prevent the introduction of salt water into the canal and, *inter alia*, remove the attendant risk that it could leach onto adjacent fields:

...in order to preserve the water of the said intended

canals and cuts between the River Arun and Chichester Harbour from any mixture of salt water, the same shall not be supplied by any water out of the said harbour of Chichester and in case the same is supplied from the River Arun, then it shall be supplied at such times of the ebb tide as shall be not less than two hours after high water and from there not exceeding one hour after flood... in order to prevent the water of said intended canals and cuts from becoming putrid and stagnant and thereby noxious to health...

This meant that the pump would need to deliver a large volume of water in a comparatively short time, a fact that would have been reflected in Rennie's specification to Boulton & Watt.

The Boulton & Watt drawings, which are to the rather strange scale of one third of an inch to the foot (1:36), show that installation was a characteristic single-acting beam engine driving a lift pump. They also give the layout of the building that was to house the engine, pump and boilers. As is the way with early drawings they are not fully dimensioned, so much of the information would have had to have been determined by scaling - as indeed it was for this analysis.

No elevations were provided for the building, but the sectional drawings, given in Figs 6, 7 and 8 (centre pages), indicate the layout: the pumping station building was 40 feet by 37 feet 3 inches in plan and divided into two parts; a single-storey section containing two 21-foot long boilers, and a three-storey section, 17 feet 8 inches taller, to house the engine and the pump. Both sections sat atop a deep basement. The principal frontage facing the canal was of four bays and both sections of the building were to have hipped roofs with overhanging eaves. The boiler house was topped by a tall, and impressive, tapering chimney.⁸

As has been intimated we have no photographs of the building, but it appears in the background of the painting given at Fig 1 which was made in 1888 long after closure when it was awaiting its fate.⁹ Although the fenestration matches the Boulton & Watt drawings, the roof to the engine house does not - instead of an overhanging pitched roof it is shown as having a parapet, above a dentilled cornice, hiding either a flat or an 'M' roof. Architecturally the building can be seen to have something of an Italianate flavour.

Inside, running across the width of the engine house, is the 'lever wall' which carries the beam of the engine. It is labelled as being '3' 6" or 3' 9" thick - the

resident engineer presumably being left to decide which dimension to use! A three-foot high tunnel passes beneath the lever wall to link the engine and boiler houses, and is covered by 18-inch thick stone blocks.

The single acting engine has a 42-inch cylinder and eight-foot stroke. The beam (indicated only by its centre line in Fig 7) is 25 feet long between its 'small ends' and is connected to the piston and pump rods by Watt's parallel motion.* Its trunnions are carried in a cast-iron bearing block which rests on a pair of resilient 'spring beams', 13 inches square, spanning between the end walls and resting intermediately on the lever wall. The spring beams are each in three sections scarfed together transversely. The centre section, 10 feet overall, is of oak, the outer sections being deal. The beam also drives an air pump situated next to, but 10 feet below, the cylinder and a hot water pump situated on the other side of the lever wall at high level. The cylinder rests on a masonry 'platform' – actually a plinth - 10 feet high, its top 18 inches being of stone, the remainder of brickwork. The cylinder is secured by long holding down bolts passing down through the plinth into the 18-inch stone blocks spanning over the tunnel. The dimensions of, and the means of anchoring, the bolts are not given but the pockets are specified as being '4 or 5 inches square in the platform but 2½ or 3 diameter thro' the stones'. It is likely that the bolts, which are shown projecting into the tunnel, were secured by nuts against patress plates but these would have had to have been fitted from within the confines of the tunnel by a boy – and a fairly small one at that.

The pump barrel, shown in Fig 9, sits in the well and has a working bore of 38 inches. It is 26 feet long comprising four castings bolted together through flanges.¹⁰ The whole assembly is supported at the bottom by a pair of cast iron beams, 19 x 6¾ inches in section, spanning across the well and bearing against the sides of the bell-mouth casting.

It can be seen in Figs 7 & 8 that the well, which sits within the footprint of the building, is nine feet in diameter with 18 inch walls thickening to 21 inches at the base, and a floor indicated as being of 'planks on inverted arch'. The pump is offset from the centre of the well by two feet and its bell mouth is two feet

* This was an ingenious system of links that compensated for the fact that the pump and piston rods were constrained to move in a vertical plane whilst the ends of the beam, to which they were connected, described an arc.

above the floor.

At the side of the building (see Fig 6) an opening is indicated as being 'for pump spout'. The longitudinal section (see Fig 7) shows a vessel sitting atop the barrel which represents this 'spout'. There is no site plan so the actual means of transferring the water into the canal is unspecified, but usual practice was to achieve this via a spillway.

It will be noted that there are no levels indicated on any of the drawings, the only setting-out criterion being that the top of the pump casing had to be set at canal water level (See Fig 7) – it was obviously left to the resident engineer, James Hollinsworth, to carry out a site survey, sort out the ground levels and duly instruct the contractor.

Construction of the pumping station

Once the Boulton & Watt drawings were received, site work by the contractor, Dyson & Thornton, obviously proceeded apace, the P&AN Committee of Management being able to report to their shareholders at the annual general meeting on 18 May 1819 that:

...notwithstanding a great flow of land springs which made the sinking of the well at Ford a tedious operation, it has been completed and the engine house over it is nearly finished, the erection of the Steam Engine is keeping pace with the building.¹¹

The engine was commissioned in August 1819, little over a year from the placing of the order, and was put to work, running almost continuously, to dewater the excavations for the rest of works around the site as the land springs were continuing to cause problems. These works included the construction of what was described as 'the drain then constructing for the purpose of feeding the Engine Well from the River Arun'.¹²

Rennie visited Soho Works on 2 September 1819 as the following memorandum confirms:

[*Inscribed in verso*]

Mr Rennie at Soho Sep. 2nd, 1819

Portsmouth and Arundel Canal engine has been worked

The Portsea engine may go forwards

[*Text*]

Mr Rennie at Soho Sep. 2nd, 1819

Portsmouth and Arundel Canal engine set to work and performs satisfactorily. The other engine is to go

forwards without any alteration from the original proposition (33[illegible] 7/-) the particulars of that end of the canal being now settled -- Mr Hollinsworth of Chichester to be wrote to immediately and drawings made soon as possible.¹³

This obviously refers to the successful steaming of the Ford pump, the 'other engine' being the one at Portsea and '33 - 7/-' probably refers to the size of engine first proposed for there - i.e. one of 33 inches bore and seven foot stroke. In the end the engine supplied for Portsea was the same size as that for Ford, the enlargement, at the extra cost of £160, being ordered on account of the deepening of the canal there.¹⁴ The drawings for the installation at Portsea¹⁵ show that its buildings were identical to those at Ford which demonstrates that the building next to the canal at Milton, known locally as *The Old Engine House* and referred to as such by other writers, cannot have been such. It is nothing like the drawings, is too small to house a 25 foot beam engine and pump, is some 60 feet away from the well and, in any case, is of an inappropriate layout. It is most likely that the surviving building housed the lock and engine keepers, as at Ford.*

The efficacy of the Boulton & Watt pumps is demonstrated by a newspaper report of 2 October 1820 about an incident that occurred at the commissioning of that sister pumping station at Portsea:

Previous to the public trial of the engine, it was thought proper to set it in motion for a few minutes, to see that all was right, and several persons were at work in and about the cistern into which the water is pumped, and from whence it is discharged through the side of the building into the canal. When ready, the engine man gave notice that he was about to try the engine, and these men immediately quitted their position; but one of them thinking he should have sufficient time to get out some article he had left behind, jumped into the cistern, and instantaneously the pump raised such a volume of water, that in a second of time he found himself outside the building, and completely immersed in the Canal; happily the depth of water was trifling, and he was released from his uncomfortable situation without any other inconvenience than a good ducking.¹⁶

Poor chap, one's heart goes out to him, for he would never have been allowed to forget the incident. However, in those days there would certainly have

been no question of his suing his employer for damages to his reputation!

Envoi

The working life of Ford pumping station was to be short, for by 1831 it had been rendered redundant by alternative natural water sources, as this extract from the annual report for that year shows:

...it is confidently expected that the Steam Engine which was retained for occasional supply of water in case of need will not henceforward be required as the present natural supplies will prove sufficient for an extensive trade, the company not having had occasion to resort to the water from a mill they had purchased in order to command a sufficiency in the driest seasons.¹⁷

That watermill was at Runcton, and it was purchased by Lord Selsey, acting as agent for the Canal Company, in 1829. The mill, and its appurtenances which included a windmill, was acquired *in toto* for the sum of £2,300 in order to harness its stream to feed the canal. Being downstream of the canal, the mill would have been rendered useless by the diversion of its stream.¹⁸

John Rennie died on 4 October 1821 and thus never saw the completion of the Portsmouth and Arundel Navigation which, as every local schoolboy knows, was a commercial disaster, famously never paying a dividend to its hapless shareholders who continued to pour money into the ailing venture. The Ford to Hunston section of the Sussex Line had been abandoned by 1858 but the pumping station lingered on, presumably passing to new owners during the 1888 liquidation sell-off of the company's assets or being demolished by the liquidator in order to realise the scrap value of its contents. In the former case any new owner would have had no use for such a thing and would have demolished it in order to release the land. Either way, by the time the second series Ordnance Survey was produced in 1897 it had vanished.

On site today there is no sign of the pumping station, but the two cottages survive – albeit now disfigured by plastic windows - and the remains of the lower (No. 1) lock have been excavated by the Canal Group, duly marked by an interpretation board to advise passing walkers of what was once on this important spot. Hopefully, one day a photograph of Ford Pumping Station will turn up to reveal its true impact upon the landscape.

* Ađe Roberts first visited this building in 1999 and has always harboured doubts that it could have been the engine house owing to its layout being unsuitable for housing a beam engine.

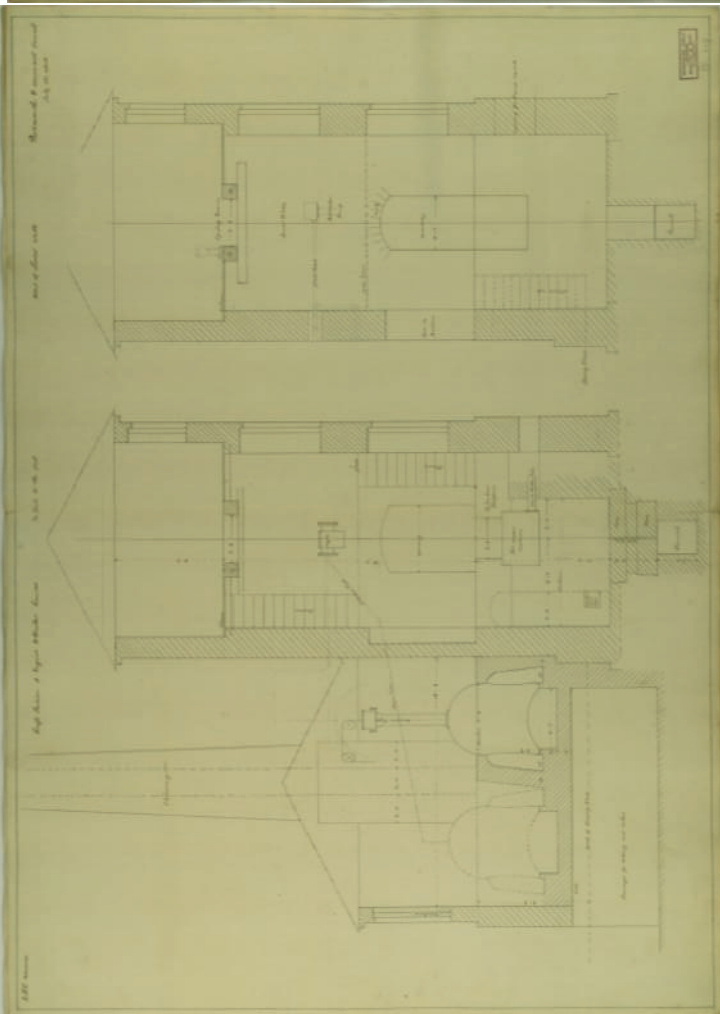

Fig. 6 Cross sections of the engine and boiler house, dated July 15th 1818. It shows the two boilers side by side. The right hand section through the engine house shows the lever wall. (Reproduced with the kind permission of Birmingham Libraries and Archives)

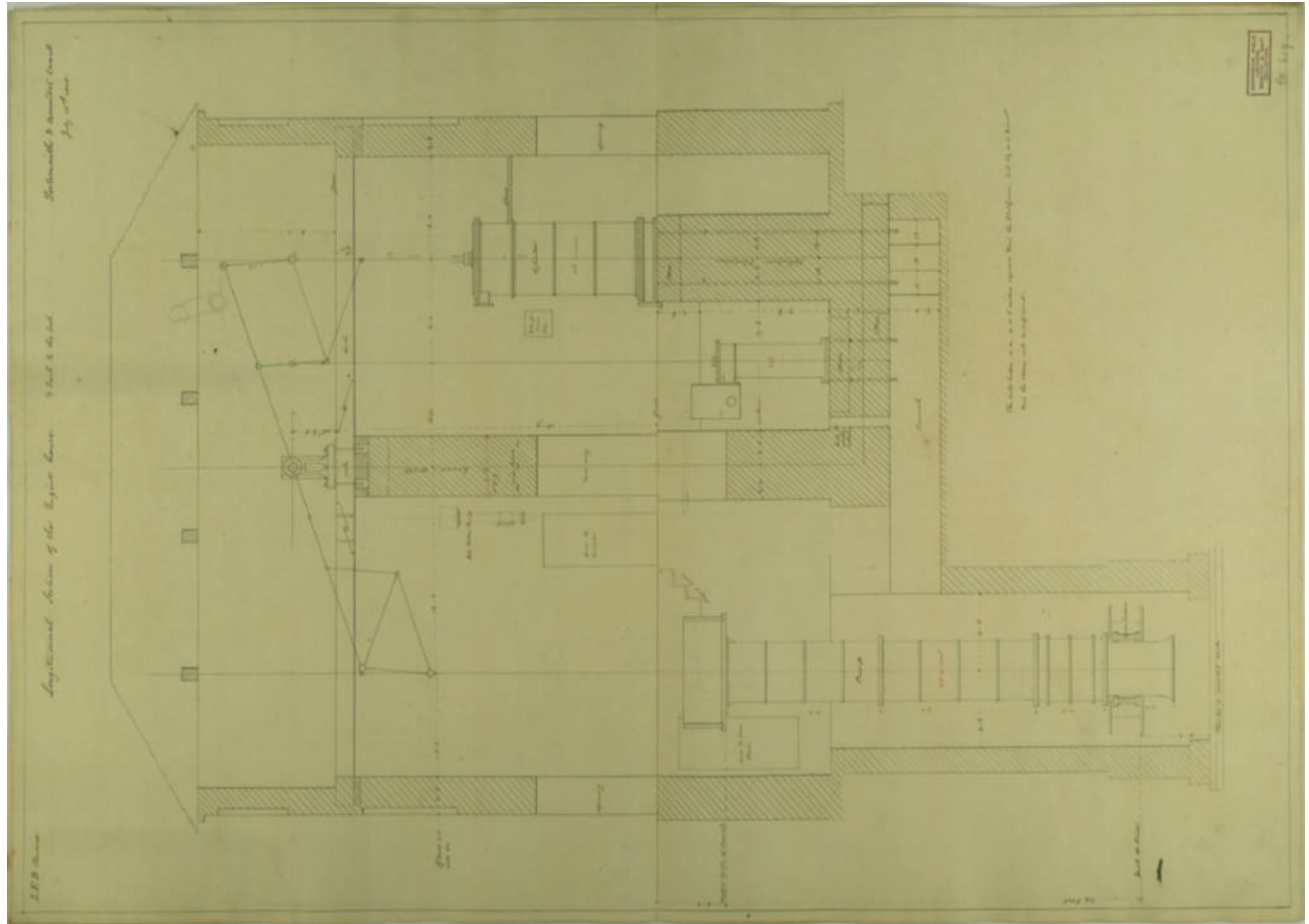

Fig. 7 Longitudinal section through the engine house, dated July 18th 1818. The engine cylinder and pump are fully detailed but the beam and parallel motion are only given in outline. (Reproduced with the kind permission of Birmingham Libraries and Archives)

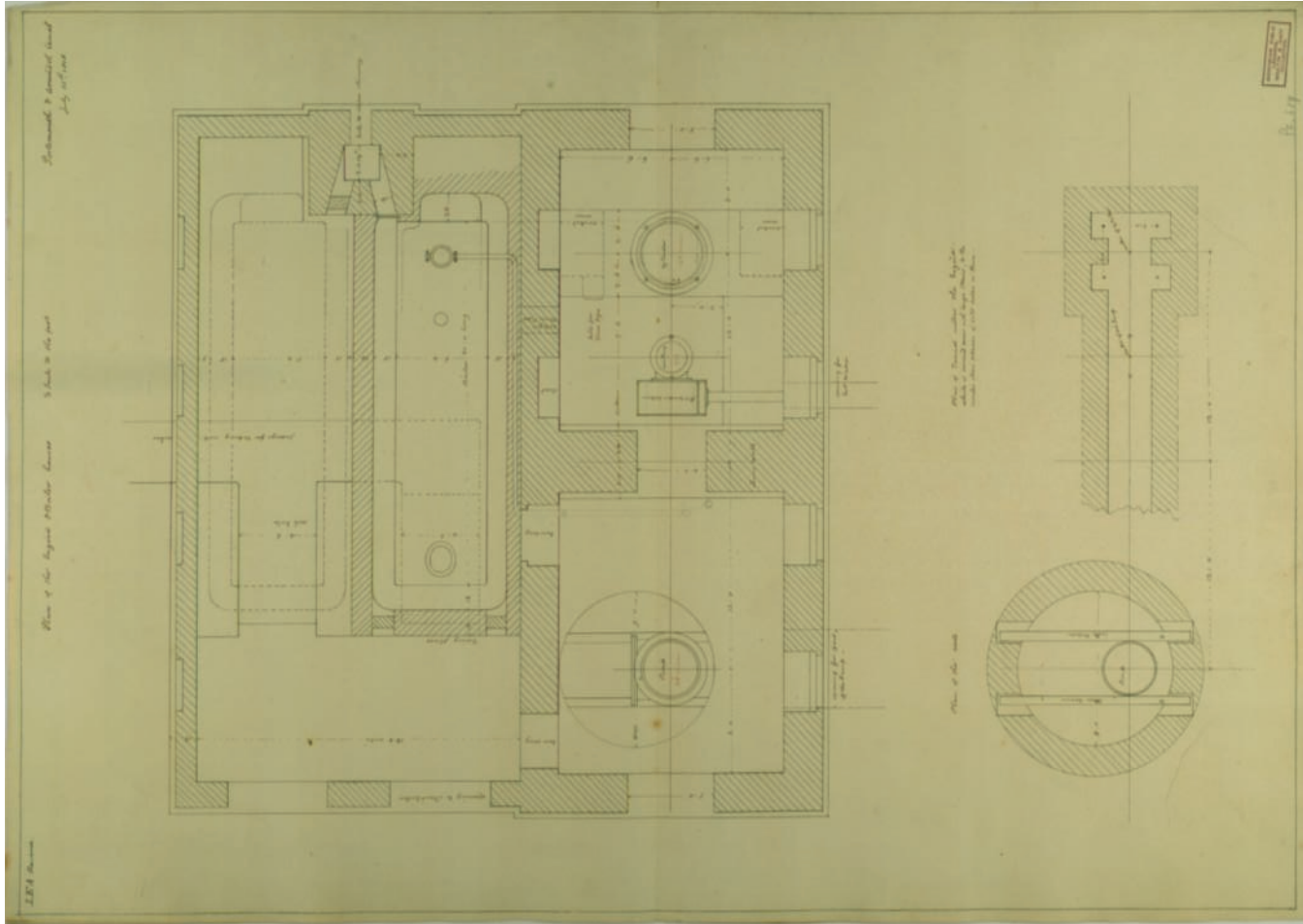

Fig. 9 The Boulton & Watt drawing showing details for the pump for Ford, dated 31st August 1818. The pump is made up from standard components (Reproduced with the kind permission of Birmingham Libraries and Archives)

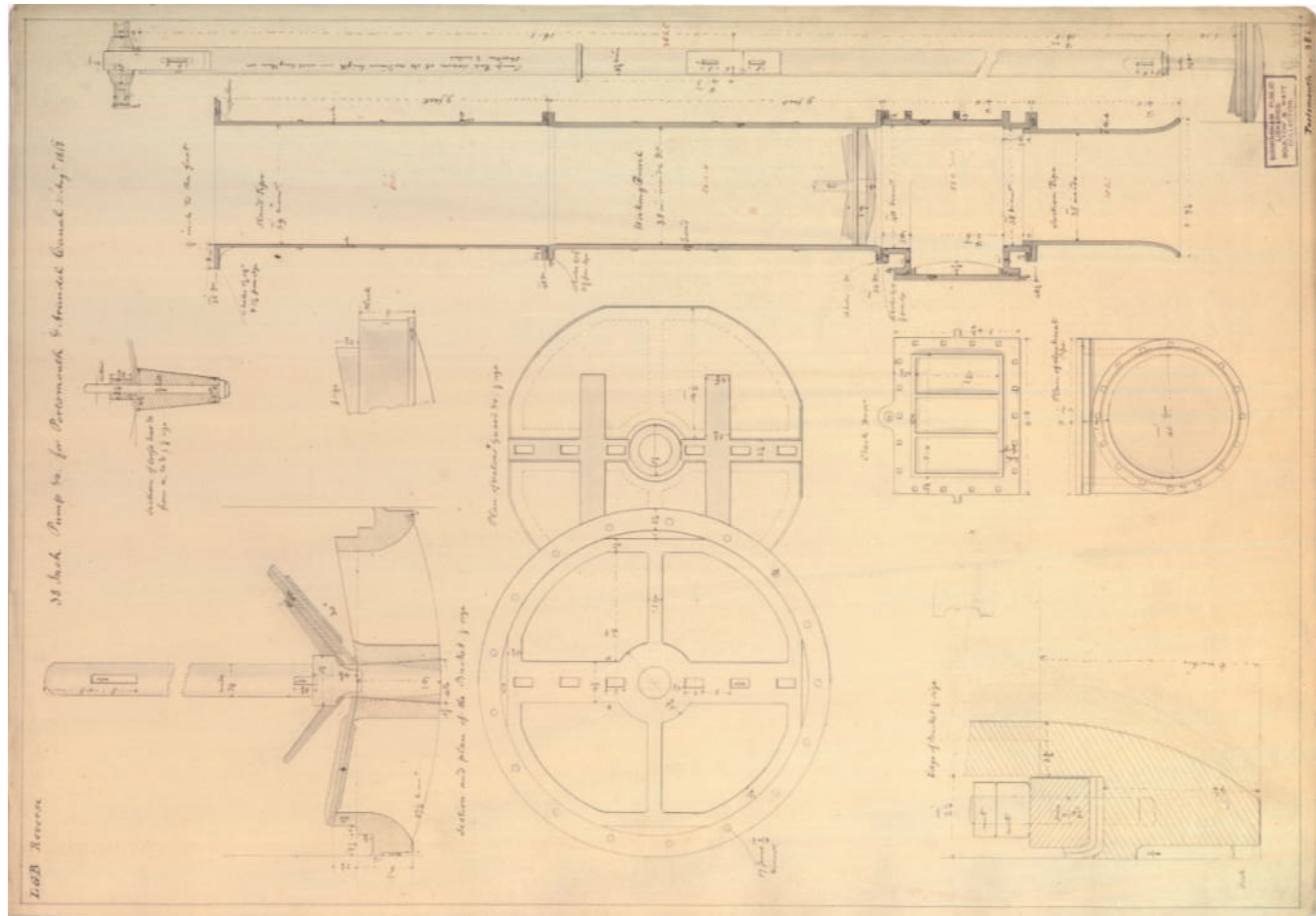

Fig. 8. Ground floor plan of the engine and boiler house dated July 15th 1818. One of the boilers is detailed and at the bottom left hand corner a section of the well is given. This drawing also gives the fenestration of the building. (Reproduced with the kind permission of Birmingham Libraries and Archives)



Fig. 10 The surviving cottages at Ford built to house the engine and lock-keepers. (Author)

Acknowledgements

Credit is due to Adge Roberts for making the trip to Birmingham and opening up this veritable treasure chest, and I would like to thank the very helpful staff at Birmingham Central Library who gave him access to the B&W Archive, supplied scans of the drawings and kindly granted me permission to publish them here. I would also thank the ever-helpful staff at West Sussex Record Office, where the rest of this research was carried out, and who kindly gave permission for the illustrations at Figs 1 and 2 to be reproduced.

References

1. 57GeoIII Cap 63
2. Green, Alan H J *The History of Chichester's Canal, Sussex Industrial Archaeology Society*, Third Edition 2009
3. Delieb, Eric and Roberts, Michael *The Great Silver Manufactory- Matthew Boulton and the Birmingham Silversmiths 1760-1790 Studio Vista*, London 1971
4. Skempton, E W (Edit), *A Biographical Dictionary of Civil Engineers in Great Britain and Ireland*, Vol 1 1500-1830. Thomas Telford (Institution of Civil Engineers) London 2002
5. Birmingham Libraries and Archives, Boulton & Watt Archives MS3147/3/3181/16
6. WSRO Raper 298 a copy of the Report of the Committee of Management to the AGM on 18 May 1819
7. Mason, Shena (Edit) *Matthew Boulton – Selling what the world desires Birmingham City Council & Yale* 2009, it includes the catalogue of the Matthew Boulton bicentenary exhibition at Birmingham in 2009.
8. Birmingham Libraries & Archives, Boulton & Watt Archive, MS 3147/5/ 619 B-D
9. WSRO PD 1607. This is catalogued as being a black and white photograph of a watercolour. The painting is signed *EH 1888*.
10. Birmingham Libraries & Archives, Boulton & Watt Archive, MS 3147/5/ 619A
11. WSRO Raper 299 a copy of the Report of the Committee of Management to the AGM on 18 May 1819
12. WSRO Raper 300 a copy of the Report of the Committee of Management to the AGM on 16 May 1820
13. Birmingham Libraries & Archives, Boulton & Watt Archive MS 3147/3/319/6
14. Birmingham Libraries & Archives, Boulton & Watt Archive MS 3147/4/319/8 a letter from Rennie to Watt dated 7 October 1819.
15. Birmingham Libraries & Archives, Boulton & Watt Archive, MS 3147/5/620
16. Cuthbert, Ted, *Portsmouth's Lost Canal*, Portsmouth Urban Studies Association 1991, quotes the newspaper article but the name of the organ bearing it is not given.
17. Portsmouth City Library LP626 a copy of the 1831 Annual Report.
18. WSRO AddMS 8926 A memorandum of agreement, dated 25 July 1829, between John Newland of Chichester and The Rt Hon Henry John, Lord Selsey, Baron Selsey of Selsey, to the sale of Runcton Mill to the Canal Company. The purchase had to be completed by 29 September 1829.

HOLLINGBURY AND THE AIRBUS

Peter Groves

Schoolboy fascination

Many schoolboys of the early 1980s were well aware of and fascinated by the true story of huge aircraft wings being manufactured in England and then flown down to Toulouse in France for assembling into the Airbus. However, both the schoolboys and the majority of people in Brighton will have no idea of the connection between Hollingbury and this intriguing fact. It will surprise most residents and visitors alike, that the city of Brighton, best known for tourism, conferences and entertainment, was involved at all with this story.

Biggest Machine Tool

Another surprising detail of this story is the fact that in the early 1980s, the biggest computer-controlled metal-cutting machine tool in Europe, if not the world, was designed and built in Hollingbury. This enabled the huge aircraft wings to be manufactured in the UK using latest technology, with new cost-effective production methods, before being flown to France for final assembly into the Airbus.

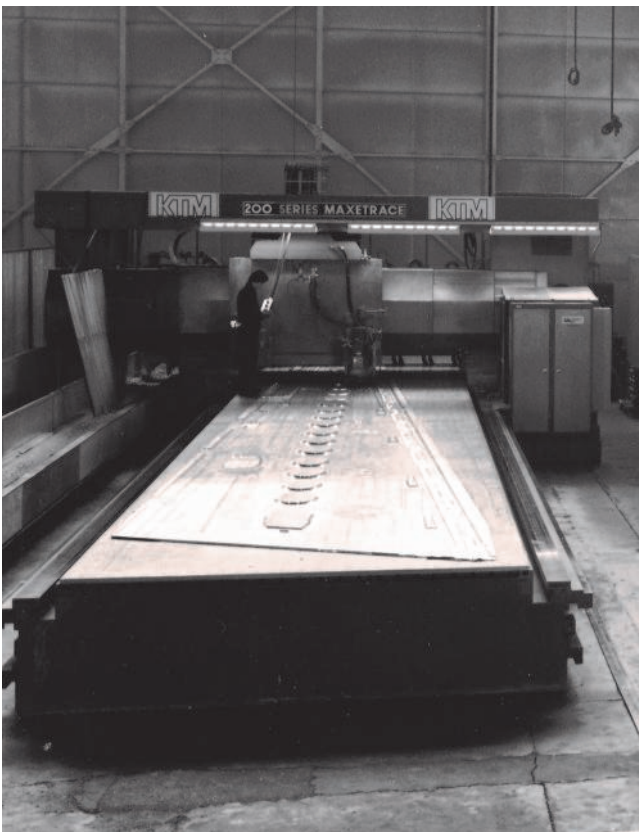

Fig. 1 Proven technology, the standard 200 Series Maxetrace

A tale of two manufacturers

Machine tool manufacturer CVA/Kearney & Trecker had been in the Brighton area for many years; however the 1970s were tough times of economic gloom, with the three-day week, power cuts and strikes. Although at the end of the 1960s they employed over a thousand people, the 1970s brought consolidation of facilities and many job losses. Redundancies were announced, it seemed, on a regular basis; the Company was in trouble. Also in similar trouble was Marwin Machine Tools of Leicester. Kearney & Trecker manufactured a range of general-purpose CNC metal-cutting machines, and a range of special-purpose automotive machines, Marwin produced large aerospace aluminium-routing machines. Both companies were in financial difficulties, and in 1973 a merger was approved by the then Conservative administration that provided £1,450,000 in assistance under Section 8 of the Industry Act. This was followed by a further £1,900,000 in 1976 under the same act, by the Labour administration¹.

Consolidation to Hollingbury

Following the merger the name was changed to Kearney & Trecker Marwin (KTM). The old Marwin facilities in Leicester were gradually wound down and production of Marwin products was switched to the Hollingbury factory. Due to its large size and big overhead cranes the Hollingbury factory was well suited to the huge Marwin aerospace machines.

Airbus/British Aerospace background

In September 1967 the British, French and German governments signed an agreement to start the development of the 300-seat Airbus A300.² Airbus Industries was a consortium of European aviation firms with the purpose of strengthening European aviation technology and competing with the American giants such as Boeing, McDonnell Douglas and Lockheed. British Aerospace was formed 1977 following the nationalisation and merger of a number of large British aircraft manufacturers. In 1979 British Aerospace joined the Airbus consortium³, and shortly afterwards following the British Aerospace Act 1980 the government sold its shares and the company became a plc.⁴ Now part of the Airbus consortium, British Aerospace would invest in new capital equipment to produce the Airbus wings and guarantee the high

production levels required to meet an ever-increasing demand.

Well placed to win prestigious order

Marwin in particular had a strong history of sales to UK aircraft manufacturers. Kearney & Trecker has a strong background in high technology design and production. This placed KTM in a strong position to win the prestigious order for profiling machines to produce the aluminium wings.

200 Series Max-E-Trace, innovation

The standard 200 Series Max-E-Trace high-speed routing machine was already proven technology, installed and in production at many sites around the UK. However the proposal by KTM was to manufacture a special huge 5-axis 200 Series Max-E-Trace,

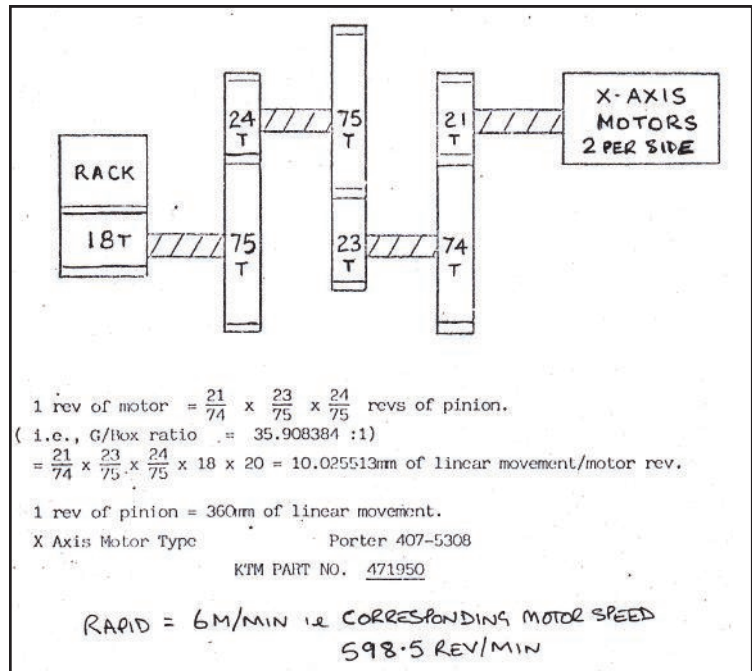

Fig. 2 X axis gearbox configuration and calculations, from the engineers' initial design specification

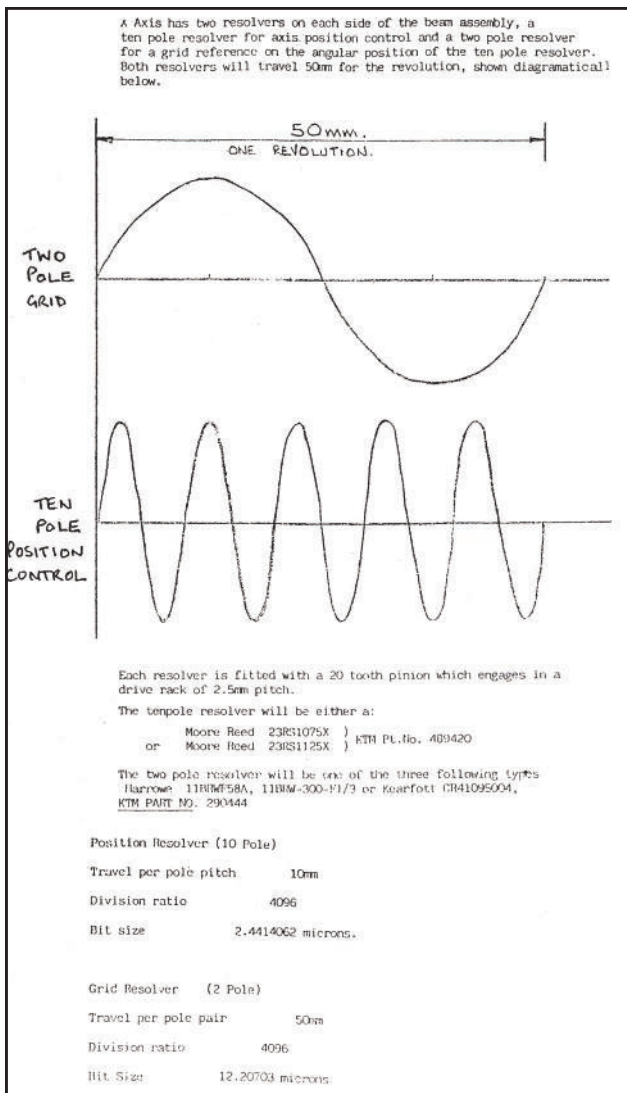

Fig. 3 X axis, dual resolver positioning, shown diagrammatically, from the engineers' initial design specification

with two independent cutting spindles, mounted on two independent beams, which would travel along a bed with an overall length of 66 metres, as long as three cricket pitches. There were distinct advantages with this solution: firstly, and most importantly, it would have the capability to guarantee the high production levels required by British Aerospace. The key to this was that two wings sections would fit onto the 66 metre long X-bed, both being cut simultaneously. Secondly, the 5-axis would have the capability to cut the intricately complicated shaped wings originally developed by Hawker-Siddeley. Furthermore, there were other advantages of having one huge machine: it would take up far less floor space than two independent machines and would use a common power source.

Order won

The order was eventually placed with KTM in 1981, with an 18-month programme agreed for final design and manufacture. British Aerospace engineers then made regular visits to Brighton from Chester to check on progress and agree any technical issues.

X - Bed, technical data

The X-axis bed was constructed from precision planned cast iron sections bolted together and accurately aligned using an auto-collimator. Each bed section was 2 metres long and over 1 metre wide, with three fitted across the width, giving an overall bed size

of 66 metres long by 4 metres wide. Huge precision hardened steel guide ways were fitted to each side of the bed, with drive racks positioned directly underneath; these had to be heavy duty to take the weight and move the huge Y-axis gantry beam along the linear X-axis. The total weight of the 66 metre X – bed was estimated at 500 tons.

Y-Gantry Beam, plus Z, A and B axis, technical data

Both of the two Gantry Beams housing the Y-axis were constructed from thick fabricated stress relieved steel and were over 4.5 metres wide. Each Gantry Beam travelled along the fixed X – bed, carrying the rest of the machine as a self-contained assembly. The Y-axis had a full cutting stroke of 3.85 metres driven by a DC motor and recirculating ballscrew. Along with the Y-axis, the Z, A, and B axis were also mounted on the Gantry Beam. The Z-axis vertical Head Slide being linear with a 0.45 metre cutting stroke, and the A and B axis being angular cutting axes of +/- 30 degrees and +/- 60 degrees respectively. Also mounted to this was the 10,000 rev/min. water and air-cooled cutting spindle, driven by an 80kW three-phase router head powered by a Brentford Electric inverter drive. Additionally the ancillary equipment was completely self contained on the travelling Gantry Beam; hydraulics,

lubrication, coolant and electrical panels, giving a total weight of the Gantry beam at over 35 tons! The combined overall size of the machine was 66m (216ft 6ins) long, 8.75m (28ft 8ins) width, 3.5m (11ft 6ins) high.

Technical difficulties

One of the many technical difficulties to overcome was how to achieve high responsiveness and accurate positioning of the massively heavy Gantry Beam along the X-axis bed. The Gantries of similar but smaller machines were driven on only one side, with the opposite “slave” side following. However the Gantry on 200 Series Max-E-Trace machine was driven on both sides of the bed, using anti-backlash gearboxes each with two DC servomotors and drive pinions engaged into the rack mounted on each side of the X-axis bed. The pinions of each gearbox were always driving in opposite directions at 10% torque at standstill to remove any backlash. When a positive move was commanded, the gearbox positive motor would overcome the resistance of the anti-backlash negative motor, which continued to drive in the opposite direction, and move the beam in the positive direction. The opposite was true for changes of direction, ensuring that, while, mechanically, slack existed, it was always eliminated and not transmitted to the cutting spindle causing

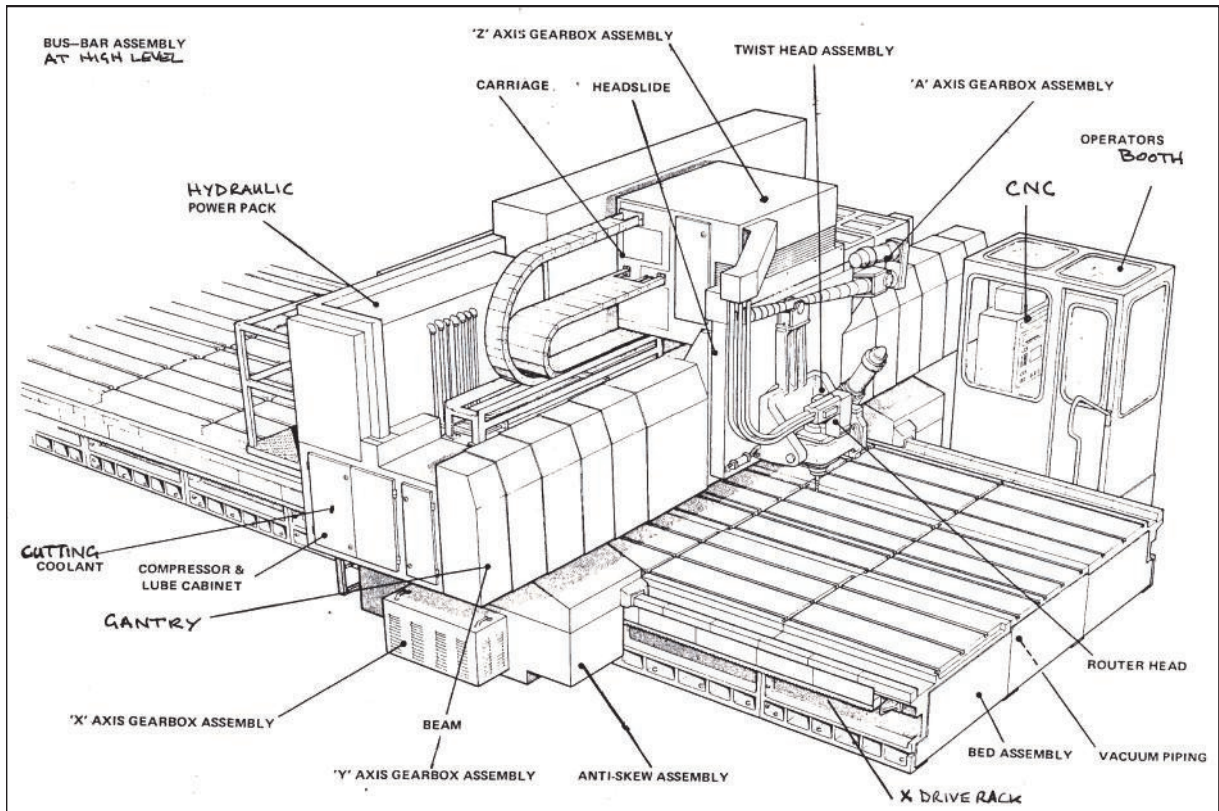

Fig. 4 The 200 Series Maxetrace schematic, from the Service Manual

poor accuracy. It was also necessary to synchronise the two gearboxes to keep the Gantry moving square to the bed. This was achieved by having “measuring” resolver feedback on each side of the bed driven by separate “high precision” rack and pinion. Two resolvers were used on each side ‘coarse’ and ‘fine’ resolutions each monitored against each other and each side. This method proved successful in eliminating skew of the beam and maintaining very high positioning accuracy of 2.4414062 microns.

Common power source

Each beam assembly was connected to the power supply via a sliding contact three-phase 415V 300A busbar system which was installed along the entire length of the X-axis bed, mounted 3 metres above floor level.

Vacuum clamping

The huge raw aluminium alloy billets, which were to be machined into wing skins, were clamped to the machine by vacuum. Unlike conventional

mechanical clamping, a powerful vacuum pump removed the air from under the billet, which was positioned on top of a self-sealing vacuum chuck thus utilising the air pressure above the billet to hold the billet down and flat onto the machine bed. This allowed the cutter 100% access to the billet for machining. There was a second, smaller busbar system, which carried the signals from the vacuum clamping equipment to the machine CNC control, to warn of vacuum failure. Failure of the clamps could cause very expensive scrap; however, this was extremely unlikely as triple redundancy equipment was used. If one vacuum pump failed, the second would automatically switch to operational mode and likewise if the second failed, the third would automatically take over.

CNC Control

The heart of the machine was a Kongsberg 2000M Computer Numeric Control. All machine functions were interfaced in software, including running the computer generated “part program” that controlled all axis and spindle during the complex cutting of the aluminium alloy billets. The CNC 2000M was

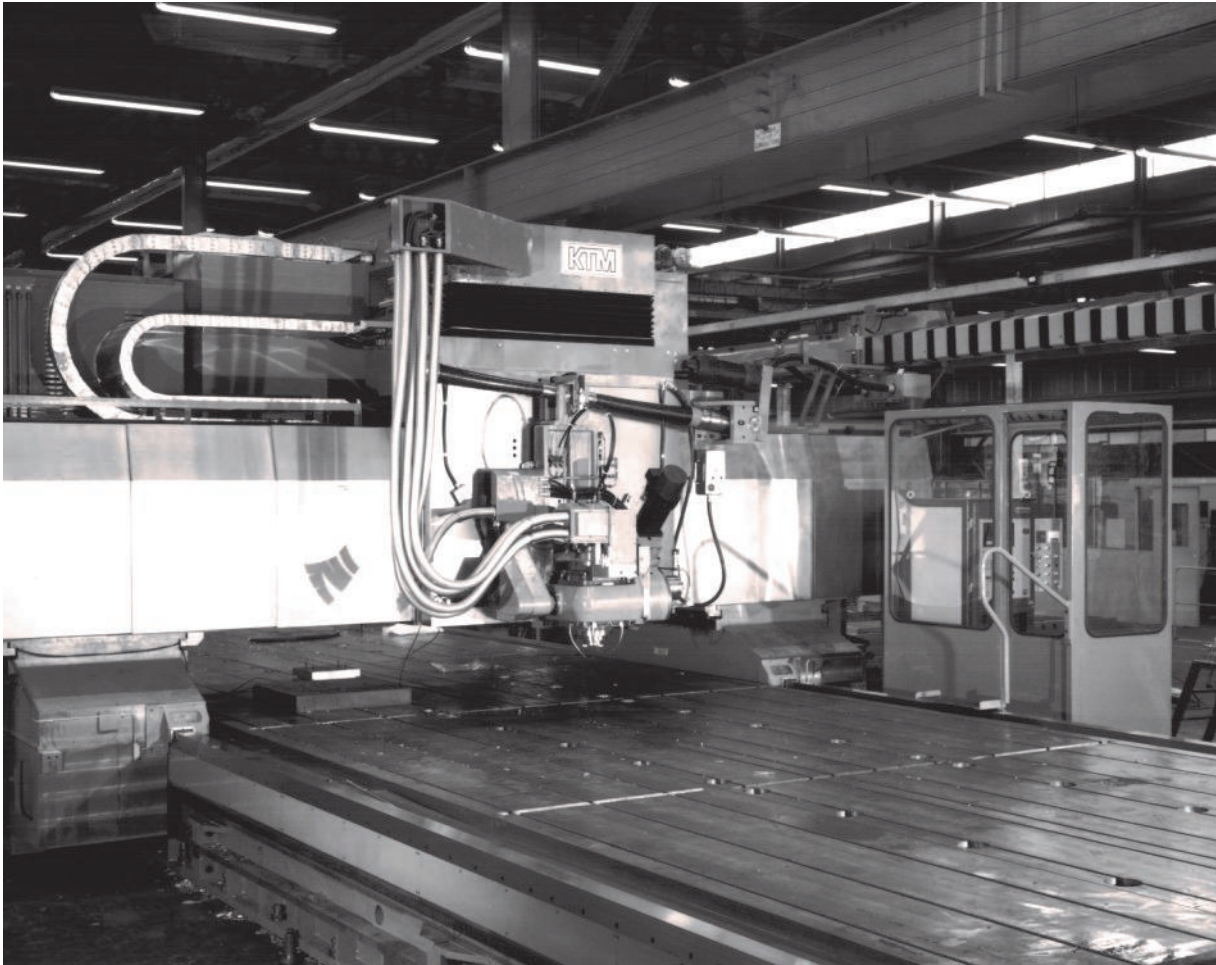

Fig. 5 The 200 Series Maxetrace, on test in the Hollingbury factory

based around a NATO KS500 minicomputer, adapted for use as a CNC by Kongsberg Vapenfabrikk in Norway, with the first prototype being built in 1965 and production versions placed on the market from 1970⁵. This was one of the earliest controllers available to machine tool builders and was running Assembler software, whereas earlier machine controllers were hardwired.

Transport to BAe Chester and installation

Due to the huge size of the X-bed, sections were assembled in the Brighton factory, inspected for geometry and then stripped down into single manageable units for transportation and reassembly at BAe in Chester. However, as the two gantries were so huge, and had taken hundreds of man-hours to assemble, it was decided to transport the completed 35-ton assemblies in one go! The maximum load limit of the overhead cranes in the Brighton factory was 30 tons, not quite enough. A huge mobile crane was brought in to lift the gantry on to a low loader lorry. The gantry was so wide and overhanging the lorry that a police escort was required on its slow journey to Chester, for final assembly onto the already installed and prepared X-beds. Installation and commissioning on site was carried out to strict procedures by KTM service engineers.

Cutting of wing skins and wing performance

For the machining of wing skins, a single billet of aluminium alloy, is clamped to the machine by vacuum, and pre-determined datums confirm to the CNC the exact location of the billet. A high speed routing cutter, as defined by the part program, gradually removes 80 – 90% of the aluminium billet, in a cutting process that could take many hours;

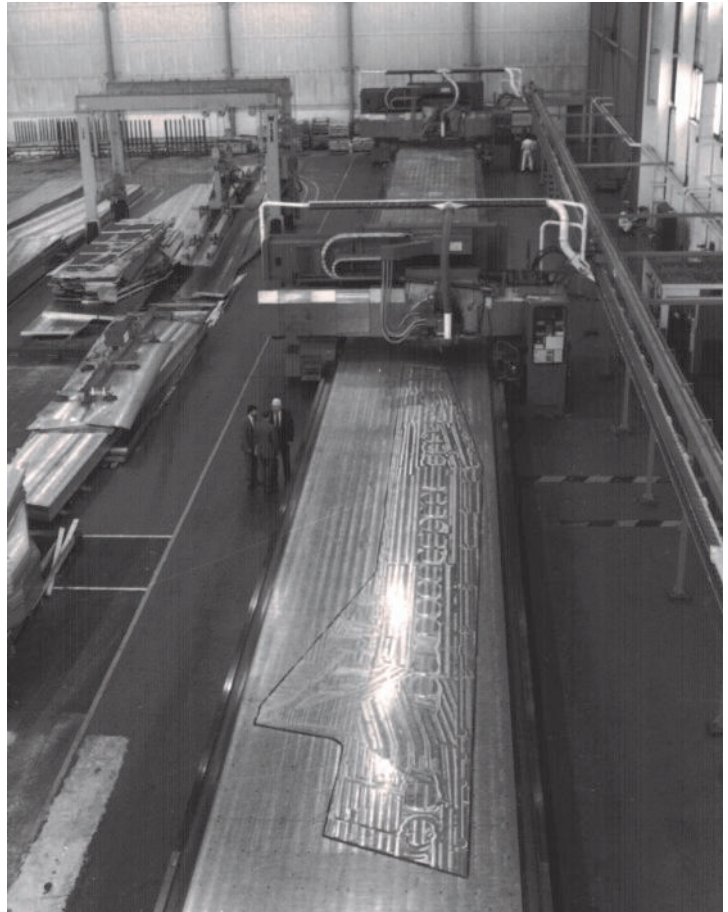

Fig. 6 The 200 Series Maxetrace in production at British Aerospace Chester after installation

precision machining is critical for many reasons! During take-off the stress on the wings is highest, with up to 100,000 litres of aviation fuel stowed within, the wing tip rises by a full four metres as the aircraft gets off the ground! It's for these reasons that attention to exact size is of paramount consideration and weight is so important. Every unnecessary scrap of metal must be machined away; however, removal of too much could cause weakness - the wings must have the required strength.

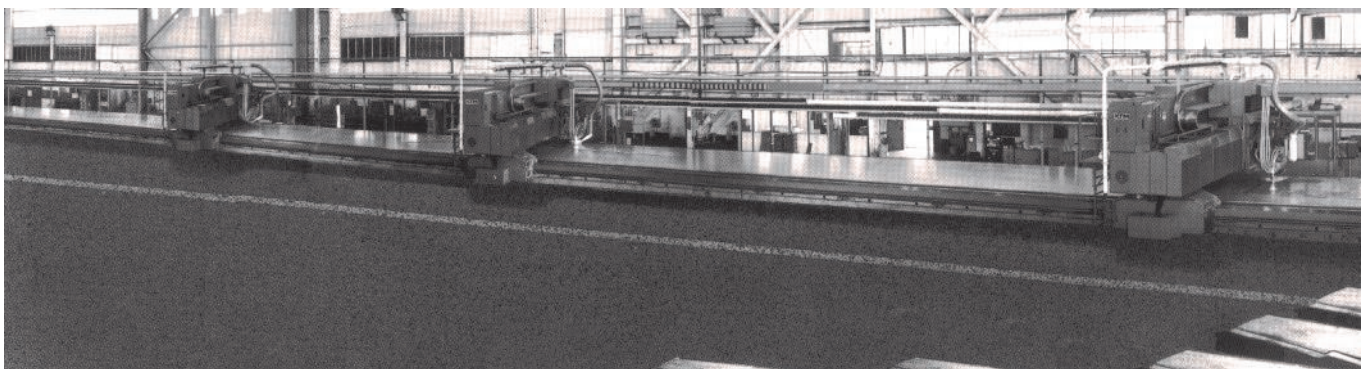

Fig. 7 The 200 Series Maxetrace, after the 1988 upgrade, showing the 3 gantries and now 87 metres in length

1988 Upgrade

By the mid-1980s, with air travel ever increasing, an extension to the 200 Series was planned. This was completed in 1988 by the addition of another 21 metres of X bed and a third 5-axis gantry and cutting spindle. This made the machine 87 metres long, more than four cricket pitches, with a total weight of around 750 tons. It was now capable of simultaneously cutting three wings skins each, 24 metres long, or even the latest larger Airbus wings, which were now over 40 metres long.

Schoolboys of the 1980s

While schoolboys of the 1980s were well aware of huge aircraft wings being flown to France; they probably speculated on how this was achieved. It was made possible thanks to the huge Boeing Super Guppy transport plane (at Boeing it was a standing joke that “every Airbus was delivered by Boeing”!) Like the fascination the schoolboys had then, readers now may wonder how it was possible that this huge machine, with massive X-axis motors fighting against each other to eliminate backlash, was able to position the 35-ton Gantry beam, to an accuracy of just over 2 microns, twenty-five times smaller than the thickness of a human hair. It was all made possible thanks to KTM and the engineers from Brighton!



Fig. 8 The Super Guppy Transport Plane, used to transport Airbus components between European factories

Glossary

Machine Tool – cutting machine, for example lathe, milling machine

CNC – Computer Numeric Control

Special Purpose Automotive Machines – Machine normally dedicated to the cutting of one complex car component in high volume, eg cylinder head

Routing – a high speed rotary cutting process

5-Axis – each axis able to produce a simple “cutter path,” with 5 axes working simultaneously, very complicated cutter paths can be produced. Normally machine tools have 3-axis as standard.

Auto-collimator – precision measuring instrument for measuring angles and straightness, prior to laser measurement becoming more common.

Guide ways – hardened steel, precision ground guides to enable the axis to move accurately and smoothly with minimum friction

Recirculating ballscrew – type of screw thread used to move the axis, where friction is reduced by the use of ball bearings between the male and female thread

Backlash – looseness or clearance, normally associated with gears

Resolver feedback – electromechanical rotary measurement device, which sends signals back to the CNC enabling absolute position to be determined

Micron – one millionth of a metre (2.4414062 microns being approximately 25 times smaller than the thickness of a human hair)

Part Program – a program of instructions to the CNC for cutting the component

Sources

All technical information has been provided and checked by KTM Design Engineer Mr P. Gibney, who worked on the 200 Series project. Additionally, much of the technical information has been cross-referenced with the 200 Series Maintenance Manual, copy owned by Mr P Gibney.

1. KTM “Press Cutting Book,” owned by the author
2. http://plane.spottingworld.com/Airbus_A300
3. <http://www.airhighways.com/airbus.htm>
4. <http://www.baesystems.com/Businesses/RegionalAircraft/AboutUs/History/index.htm>
5. Kongsberg 2000, mid 1970s Sales Brochure, copy owned by the author

Photo Credits

Figs. 1, 2, 3, 4 - Peter Gibney, KTM Design Engineer 1971-1994

Figs. 5, 6 - Pat Bates, KTM Sales Engineer 1970-1994

Fig. 7 - Dick Duly, KTM Software Engineer 1972-1994

Fig. 8 - Wikipedia

TURNPIKES TO BRIGHTON

Brian Austen

Turnpike development in the period before 1770 had connected the administrative and commercial towns of the County of Sussex with London. The improved road network also provided the means by which agricultural produce could reach the burgeoning London market, enhancing the rental levels obtained by Sussex landholders. Coastal settlements were not however served by turnpikes, with the exception of Hastings which was connected by 1753, as sea transit could provide routes to other coastal towns and London. Fish was one of the few commodities of the Sussex coast which used roads to reach inland

markets including London. This was to change, and Brighton led the way as it developed as a pioneering sea-bathing resort. Visitors were few and accommodation and facilities basic until 1750, but over the next thirty years the pace of development accelerated rapidly. This provided not only medical care, following Dr Richard Russell's establishment in the town at the seaward end of the Steine in 1752-53, but commercial entrepreneurship added accommodation, libraries, places of assembly, theatres and shops aimed to meet the needs of affluent visitors¹. A guide of 1783 reported that there had been "very considerable improvements ... within these few years"². Although a slow, two-day, coach service via Lewes was available from the 1740s it was not until 1756 that a twice-weekly

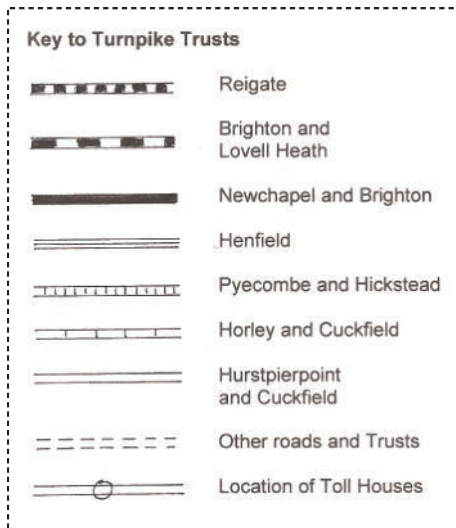

Key to Tollhouses

- | | |
|--------------------------------------|---------------------------------|
| 1. Preston | 20. Hapstead Green |
| 2. Patcham | 21. Lindfield |
| 3. Stone Pound | 22. Clewewater |
| 4. St. John's Common | 23. Ditchling |
| 5. Slough Green | 24. Ditchling South |
| 6. Bigges Farm | 25. Hill House (Ditchling Road) |
| 7. Handcross | 26. Keymer Lodge |
| 8. Ifield Bar | 27. Terry's Cross |
| 9. Crawley | 28. High Cross |
| 10. Ansty | 29. Poynings |
| 11. Bolney (Cross Posts) | 30. Dale |
| 12. Oakendene | 31. Muddleswood |
| 13. West Grinstead (Champion's Gate) | 32. Hickstead |
| 14. Buck Barn | 33. Bolney |
| 15. Froggett Heath | 34. Warninglid |
| 16. West Park | 35. Horley |
| 17. Wallage | 36. Worth |
| 18. Wallage Lane | 37. Norfolk Arms |
| 19. Turners Hill | 38. Cuckfield (Whitman's Green) |
| | 39. Little Ease |

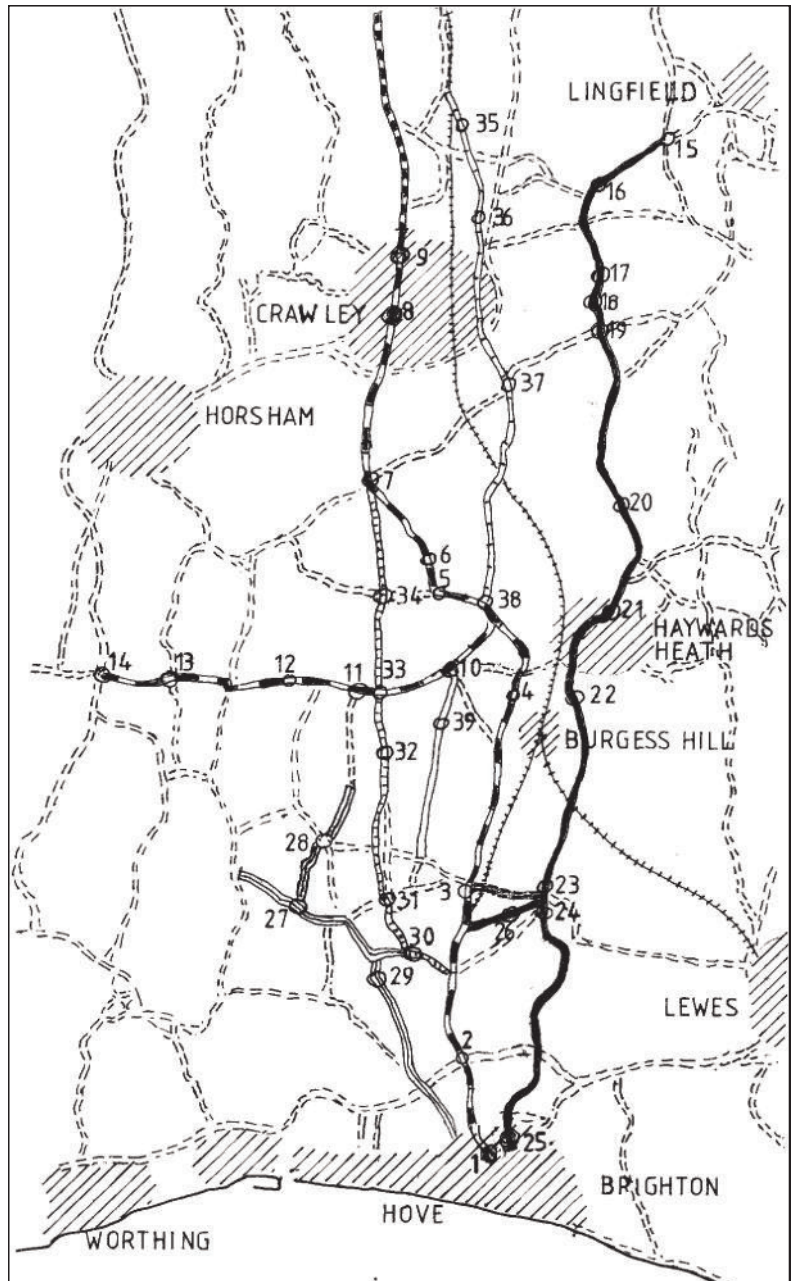

Fig. 1 Map of turnpikes c.1840 (Ron Martin)

service appeared in the summer months that could reach the town from London in a day. A competitor arrived in the 1760s but it was 1774 before a daily service was available, improving to four daily services in 1788³.

The improved coaching provision paralleled road improvements. No turnpike connection to Brighton existed until 1770 but in that year alone three turnpikes were opened providing three different routes to the town from London. These were:

- The Lovell Heath and Brighthelmstone Trust commencing at the County border, north of Crawley, and routed via Cuckfield, climbing Clayton Hill and entering Brighton through the villages of Patcham and Preston.
- The Newchapel and Brighthelmstone Trust diverging from the existing City of London and Wych Cross turnpike at Newchapel near Lingfield, and routed through mid-Sussex by way of Lindfield and Ditchling and crossing the South Downs at Ditchling Beacon.
- The Lewes and Brighthelmstone Trust connecting the recently opened Wych Cross to Malling Trust of 1759 and using the gap in the Downs to reach Brighton by way of Falmer.

The distances from London were similar, the shortest being the route by way of Reigate and Cuckfield at 54 miles, while that by way of East Grinstead and Lewes was 59 miles if through Uckfield, shortened to 57 miles if the road from Wych Cross through Chailey was selected instead. A longer route through Steyning and Horsham was favoured by some coaches involving a 62 mile journey. Coaching proprietors seemed in the main to avoid the route over Ditchling Beacon because of the gradients, though the other roads were not entirely free from long, and even steep, ascents and descents.

With the growth of Brighton and the consequent expansion of coaching traffic and rivalry, competition often was on the basis of journey time. Gradients were to be avoided if possible. The opening of the Pyecombe and Hickstead road through the Dale Gap in 1808 was the major development. This new route also avoided the town of Cuckfield reducing distance and time. It was now only 51½ miles to London and a Brighton guide of 1831 claimed that "journeys are performed, frequently under five hours". The older routes

attempted to retain their trade and, in the case of the Lovell Heath to Brighton road, excavated a deep cutting at the summit of Clayton Hill to ease the ascent. The Newchapel and Brighton Trust was unable to compete and in a desperate effort to retain some trade built a spur road from Ditchling to the foot of Clayton Hill routing traffic on to the line of its rival and virtually abandoning the route across the Beacon.

Other Trusts were established to access at least a part of the Brighton traffic. These were:

- The Henfield Trust of 1771 using the gap at Sedlescombe
- The Horley and Cuckfield Trust of 1809, and
- The Hurstpierpoint and Anstye Trust as late as 1835

Both of these latter trusts fed traffic on to the Cuckfield and Brighton road. Along the coast Brighton was served to the west by the Shoreham and Lancing Trust initially set up in 1822 and the Brighton and Newhaven Trust of 1824 carried traffic to the east.

In 1838, near the peak of the turnpike age and with rail communication an imminent reality, Brighton's resident population was estimated to be 40,000, and this nearly doubled during the "fashionable season". In 1835 there were 21 public coach departures daily for London and services also to Lewes, Worthing, Southampton, Hastings, Chatham and Oxford. In 1835 117,000 passengers were carried between London and Brighton with an average fare of 21 shillings (£1.05) inside and 12 shillings (£0.60) outside and with an average journey time of six hours. Over 1,200 horses were employed on public coaches on the Brighton road⁴. The town also prospered because of its packets sailing for Dieppe, this being the most direct route from London to Paris. Both the coaches and the packets were shortly to be the victims of the railway. A Brighton guide of 1840 declined to include a list of coaches operating from the town "in consequence of the frequent alterations" consequent upon the railway communication "making rapid progress"⁵.

The Reigate Trust 1755

Although this Trust was initially entirely in Surrey, terminating at the border with Sussex, post World War II changes to the county border in the Gatwick area have now brought a short section of this road

within the county of West Sussex. The Turnpike covered the road from Sutton to Reigate and then south by way of Sidlow Mill to Povey Cross, though initially extended to Crawley.

Its origins date back to one of the earliest turnpike Acts passed by Parliament and the earliest for Surrey and Sussex, that of 1697 (8 Wm III c15), which covered the road from Reigate to Crawley. As with a number of early Acts, powers were vested with the Justices of the Peace who were to appoint surveyors to carry out the repairs and to receive the tolls in accordance with the schedule included in the Act. Little work was however carried out, though a causeway was constructed, beside the road, suitable only for horse riders and pack animals. A series of posts were used to separate the causeway from the road to prevent wheeled traffic using it. Powers were renewed in 1724 and 1737 but no work was carried out to improve the road for wheeled vehicles. It was not until a new Act was passed in 1755 (28 Geo II c28) that the full width of the road was improved and the route could effectively be described as a turnpike road⁶.

Improvements to the road included works to the summit of Reigate Hill and the consequent stopping up of two existing roads; in 1806 Reigate Borough agreed to widen London Road to 40 feet and buildings in the town were demolished to achieve this. Little other improvement to the line of the road was made, however, until the threat to traffic posed by the 1807 Croydon and Reigate Trust (47 Geo III c 25) which built the line of the A23 south through the gap at Merstham. The Reigate Trust sought to oppose the Bill in Parliament and had to be bought off by a promise from the new trust to pay them £200 per annum as compensation for the loss of traffic. As the traffic from this new turnpike would be fed on to the Reigate Trust they saw the need to improve their own route south of the town. Plans were drawn up and implemented for the construction of a new line 2½ miles in length from Sidlow Bridge to Hookwood Common, saving a mile in distance⁷. The old line of road is still in use today by way of Wolvers. The Reigate Trust was also responsible for the road from Drovers Green to Horley. Further improvements on the main line of road occurred in 1820 when the top of Reigate Hill was lowered. Additionally Cockshot Hill between Reigate and Woodhatch (A217) south of the town was lowered by 19 feet. Within the bounds of the borough of Reigate a tunnel was constructed in 1823-

24 beneath the grounds of Reigate Castle for the use of which a separate toll was required. This route still exists but is now pedestrianised⁸.

Powers granted by the Act of 1815 needed to be renewed in 1836, at which date the Trust controlled six gates and one side bar controlling access to the turnpike. Thereafter powers were extended on an annual basis which continued until November 1881 when the Trust was wound up. Its debts were by this time around £5,000 but the Trust had been in financial difficulties at a much earlier stage. In 1807 it was stated that arrears of interest amounted to 2½ years. The building of more direct and evenly graded turnpikes south from Croydon including the Gatton Lodge to Povey Cross Turnpike (56 Geo III c30), the line of the A23, and then direct railway competition, only made matters worse⁹.

In 1840 the Reigate Trust controlled its main line of road from Sutton to the Sussex border amounting to 19½ miles and a branch road of 12 miles in extent. The trust maintained seven toll gates and 4 side bars¹⁰. As it was essentially a Surrey trust, this survey has been restricted to the line of road south of Reigate.

Tollhouses

Woodhatch TQ 258487

At the intersection of the A217 Reigate Trust and the A2044, a mile and a half south of Reigate town centre. It was on the western side of the road just south of the junction. A late-nineteenth century photograph¹¹ illustrates the tollhouse with the Angel Inn on the opposite side of the road just beyond the junction. The building was of brick with a tiled roof and of one storey, of three bays, with a projecting centre door porch flanked by two windows. A lamp above the porch allowed tolls to be collected after dark and illuminated the toll board fixed to the front of the building. Tolls were collected here until 1881. Nothing of the building now remains.

The Reigate area was well supplied with toll gates, as a 3d (1.25p) toll was also collected by the proprietors of the tunnel under Reigate Castle, if used, and another tollhouse was situated near the start of Reigate Hill, a two-storied hexagonal building which survived into the beginning of the twentieth century¹².

Milestones

The construction of the post-war Gatwick Airport

was to substantially alter the route of the A23 road. The diversion to the east of its existing line was agreed on 29 March 1952 at a meeting of ministers from the Civil Aviation, Transport and Treasury departments and was eventually implemented for the opening of the new airport in May 1958¹³. The border between Sussex and Surrey was originally at the County Oak but the airport development necessitated the county boundaries being pushed north by about two miles and bringing Reigate Trust milestones into the County of Sussex.

TQ 279400. This milestone is shown on an OS map published in 1975, having been removed from the original road alignment, where it would have been in the middle of the runway, to the new road at Lowfield Heath. It was noted by Lionel Joseph and included in his milestone survey published in 2005. Examinations in 2009 and 2010 failed to locate this mileage marker however. Joseph states that it showed a distance of 27 miles to London. This marker was possibly similar to that at present at Horley on the A23 (TQ276427), which is a cast iron pillar of triangular cross section with a distance of 26 to Westminster Bridge on the north face and 26 to Brighton on the south face. This is typical of replacement milestones supplied by County Councils in the last years of the nineteenth and early decades of the twentieth centuries.

TQ 269421. Another displacement caused by Gatwick Airport development. The stone (fig. 2) would have originally been close to the junction of what are now two minor roads, one leading to Charlwood and the other southwards from Hookwood



Fig. 2 Povey Cross milestone

Common to the airport boundary. This would have been the junction of the original lines of the A23 and A217 at Povey Cross. The stone is of typical Reigate Trust pattern, approximately square in cross section with sides 16" in width and is 4' 3" in height and set at an angle to the road. The south face is inscribed "LONDON 26 REIGATE 5³/₈", and the north

"BRIGHTON 25⁵/₈ CRAWLEY 3⁵/₈". The stone came into the care of the Ditchling Museum and for a number of years was on display outside the museum buildings. It is now back in position on the road leading south from Povey Cross to the perimeter of the airport. This road is now a cul-de-sac which serves a business estate. The remaining stones between Povey Cross and Reigate, all in Surrey, are of the same pattern and are in place on the west of the road. All are of local sandstone.

TQ 262436 Hookwood

South face: "LONDON 25 REIGATE 4³/₈"
 North face: "BRIGHTON 26⁵/₈ CRAWLEY 4³/₈"
 27 inches above ground level south face
 15 inches wide and north 14 inches wide

TQ 261451 South of Lower Duxhurst and north of Horley Mill Lane

South face: "LONDON 24 REIGATE 3³/₈"
 North face: "BRIGHTON 27⁵/₈ CRAWLEY 5⁵/₈"
 16½ inches above ground, south face 15 inches wide,
 north face 14 inches wide.

TQ 259466 Sidlow

South face: "LONDON 23 REIGATE 2³/₈"
 North face: "BRIGHTON 28⁵/₈ CRAWLEY 6³/₈"

The full inscription is no longer visible as only the top foot is above ground.

TQ257483 Drovers Green

South face: "LONDON 22 REIGATE 1³/₈"
 North face: "BRIGHTON 29⁵/₈ CRAWLEY 7³/₈"

Although varying slightly in size they are all uniform in style being of roughly square cross section and with sides 13 to 16 inches in width and a low pyramid-shaped top.

The 21 miles to LONDON block was beside the road at TQ254498 at the entrance to Reigate but is now missing and the series is picked up again north of Reigate with the stone showing 20 miles to London.

The shortening of the distance between Sidlow and Povey Cross in the early nineteenth century reduced the number of milestones required. The old line of road had stones indicating 24, 25 and 26 miles to London and it is likely that these were moved to the new road on its completion with the 26 stone replacing that showing 27 at Povey Cross. The Reigate Trust did not abandon the old line of road which still formed part of the turnpike into the second half of the nineteenth century.

Brighton and Lovell Heath Trust (1770)

This was the earliest of the three trusts that in 1770 received powers to take over roads to the growing and fashionable resort town of Brighton. It was also the shortest of the three routes, a mere 54 miles and routed via Sutton and Reigate before joining the new turnpike at the County Oak on Lovell (Lowfield) Heath north of Crawley, then the county border. Although the shortest, its line through Sussex avoided the most populous towns, though both Crawley and Cuckfield were to benefit as important stages where horses could be changed and travellers obtain accommodation and refreshment. Alternative routes via Horsham and Lewes, though slightly longer, were able to exploit intermediate traffic from these larger towns. The route from Lovell Heath extended south through Crawley, Handcross, Cuckfield, St. John's Common (Burgess Hill), Clayton, Patcham and Preston to Brighton. The South Downs was crossed at Clayton, involving a sharp ascent in the Brighton direction. The powers granted under the original Act (10 Geo III c95) were renewed in 1791 (31 Geo III c118) and again in 1807 (47 Geo III s2 c47). To this main line was added in 1825 (8 Geo IV c39) a branch, eight miles in length from Ansty through Bolney and Cowfold and ending at Buck Barn, parish of West Grinstead. This west to east route made a junction with a number of existing turnpikes, feeding traffic on to them and receiving traffic from them in return. These trusts were:

- i. The Pyecombe and Hickstead Trust of 1808 at Bolney;
- ii. The Henfield and Cowfold Trust of 1771 at Cowfold;
- iii. The Horsham and Steyning Trust of 1764 at Buck Barn;
- iv. The Shipley Trust of 1824 also at Buck Barn.

A toll was taken on the branch section from Cuckfield to Cowfold and another from there to Buck Barn; no doubt a reflection of this traffic fed on to the road from other Trusts (27 & 28 Vict c137).

Improvements were made to the line of road between Cuckfield and Ansty in 1810 when the gradient was lowered and in 1835 when a slight diversion was made to the east in connection with the building of a new bridge over a stream south of Cuckfield Park (Highbridge). This West Grinstead branch is today part of the A272.

A further Act confirming the powers of the Trust was passed in 1846 with the final winding up of those powers on 1 November 1876 (38 7 39 Vict c39). It was one of the longest Sussex trusts with a total of 35 miles of road and control of 16 gates. Improvements to the line of road authorised by the Act of 1770 were complete by 1779 and the initial years of the Trust were uneventful. As Brighton traffic increased, the direct line of road through Cuckfield proved attractive to Brighton visitors. Coach proprietors saw merit in advertising and achieving quicker journey times and years of relative prosperity followed. The first threat came in the form of a proposal for a new turnpike road from Pyecombe, through Hickstead to Staplefield Common, though in 1827 it was extended to Handcross. An Act for the new road was passed in 1808 (48 Geo III c101). A meeting of the Brighton, Cuckfield and Lovell Heath Trustees was called on 1 March 1808 at the Talbot Inn, Cuckfield to oppose the bill for the new road. It was condemned as unnecessary as the new road would only save 1¼ miles in distance and 15 minutes in time¹⁴. Distance was, however, not the main factor for it would avoid the steep ascent of Clayton Hill, as the new road ran through the gap in the South Downs at Dale. The proprietors of the new road claimed a saving of more than an hour in time. Opposition proved fruitless and traffic diverted to the new route but as the Brighton to Lovell Heath Trust controlled the first six miles to Pyecombe and the road from Staplefield to the County border, overall toll receipts were not seriously affected. In an attempt to try to reclaim traffic, over £3,000 was spent in 1819 lowering the summit of Clayton Hill by means of a deep cutting¹⁵. The original route laid down in the 1770 Act was to proceed south from Cuckfield along the present A272 to Ansty Cross then south along the B2036 to the foot of Fairplace Hill, St. John's Common, but the 1807 Act (47 Geo III ses. 2 cap 47) changed the route which now proceeded out of Cuckfield eastwards by the A272 to Butlers Green and south by the A273 (Isaacs Lane) though the road Cuckfield to Ansty continued to be maintained. In order to shorten this new section and avoid the use of the Hodges and Cuckfield Trust road from Butlers Green, an entirely new road about three miles in length, was proposed in 1824. This proceeded directly eastwards from Cuckfield near the church to meet Isaacs Lane near Brooklands¹⁶. The advantage would have been modest and in the event no work was undertaken. Similarly a proposal in the same

year for an extension from Slough Green to meet the Henfield and Cowfold Trust's Horsham extension at Mannings Heath came to nothing¹⁷. Interest may well have been diverted away from the scheme by powers granted in the 1825 Act (8 Geo IV c39) for the new branch to West Grinstead.

The initial sums raised by the sale of turnpike mortgages between 1770 and 1775 was £6,837, sufficient to carry out the improvements. A further £4,800 was raised in 1826 for works on the new West Grinstead branch. Income achieved by leasing the gates was sufficient to cover the necessary expenditure on road maintenance and to pay the interest due to the stock holders, set at 5%. By the 1807 Act permission was given for the Trust to charge one toll between Brighton and Cuckfield and another between Cuckfield and Lovell Heath. In 1806 the gates were let for £2,000 rising in 1811 to £3,890 and 1818 to £3,965. Income continued to rise and reached £6,054.12s (£6,054.60) by 1834¹⁸. Mortgage holders were well content with the generous 5% return on their investment and none sought to redeem it.

By the late 1830s, however, the probability of railway competition had to be faced. Already there were sufficient examples in Britain of railway enterprise that had swiftly killed off any attempt at effective competition by coach and with the opening of the London and Brighton Railway on 21 September 1841 the coaching era virtually ended¹⁹. This loss of the London to Brighton coaching traffic was only one factor reducing the Trust's income, though the West Grinstead branch would have been unaffected initially. The railway line closely followed the main route of the turnpike so local traffic would decline also. In 1834 the income of the Trust had been £6,056 but by 1850 this had fallen to £1,660, a decline of 73%²⁰. Maintenance had been cut by 74% and law expenses by 55%. There was no longer the need to maintain road surfaces to a standard to sustain fast coaching traffic. One thing the Trustees were reluctant to sacrifice was the interest paid to mortgage holders which continued at 5% until 1854 when it was reduced to 3½%. Despite this, holders were concerned with railway competition as turnpike trusts, if wound up, had few assets. Debt started to be paid off from 1839 and by 1854 had been reduced to £8,004 by the redemption of mortgages²¹. This continued at an accelerating pace and by 1876 the debt had been repaid, mostly at its full face value. The powers of the Trustees ended

on 1 November 1876 and the Trust was wound up. There was at the end sufficient to reward the loyalty of the employees, the surveyor receiving £100 and even the ten labourers' sums ranging from £10 to £28²².

Tollhouses



Fig. 3 Preston tollhouse c.1840

Preston TQ 303064

Was situated immediately south of the junction of the London road and South Street, projecting into the latter, and with a gate across the London road and a side bar across South Street. The garden was one perch in extent. This was the first gate reached from the Brighton direction and when set up was separated from Brighton by more than a mile of open country. It was probably established about 1780, at the commencement of the Trust's operations. Because of its placement it was the highest earning gate on the road. A pencil and wash illustration by a local artist, Montague Penley, dating from c.1840 (fig. 3) shows a two-storey cottage with a tiled roof. The ground storey was of brick construction and the upper weather-boarded. Bay windows on both stories faced the London Road and a toll board was displayed over the front door. A lamp projected from the upper bay window. In 1809 the tollhouse was said to display a notice inscribed "No Trust" (without payment travellers were not allowed to proceed)²³. As early as 1806 the tolls were being farmed and this practice appears to have been used for much of the Trust's history.

The rapid expansion of Brighton in the nineteenth century, and the increased local traffic as a consequence, made the Preston Gate unpopular with the inhabitants of the town who by the mid century were determined to get it removed. The need of the

Trustees to renew their powers by parliamentary Act in 1854 provided just the opportunity to achieve this. A meeting of the Brighton Vestry on 9 February 1854 passed a resolution to remove the gate “to such a distance from the Town as not to impede the use of the Road for the Inhabitants and especially for the Visitors in taking carriage & horse recreation”. A Preston Gate Committee of seven gentlemen was set up to work for the removal of the gate and funds raised to cover legal costs when the bill was placed before Parliament. A copy of the resolution was “forwarded to each of the Borough & County Members”. Amongst the supporters recruited were the Marquis of Bristol, W. Conningham M.P. for the town and Alderman Wilson. A petition for the removal of the gate was signed by 200 ratepayers. In September 1854 a memorial was presented to the Trustees who initially were reluctant to sacrifice such a lucrative gate, but appreciated that strong opposition in Parliament would be detrimental to their interests, and thus a clause appeared in the renewal Act (17 & 18 Vict. C137), specifying that the Preston gate had to be removed. The tollhouse was offered by the Trust to the Trustees of the will of the late William Stanford of Preston Manor for £200 in July 1855 but a sale was not effected and in April 1856 the house and garden was put up for auction, realising £150²⁴.

Withdean

The 1854 renewal Act stated clearly that the Preston Gate in the *Parish of Preston, with the side bar thereof shall be discontinued* and specified that no toll was to be taken *south of a stone to be fixed by the Side of the Road at a point ... one hundred yards North of the House now occupied by Edward Hamshar in the Hamlet of Withdean in the Parish of Patcham*, and at the meeting of the Trustees on 1 November 1854 James Battersbee was appointed Collector of Tolls at the Withdean Gate at a wage of £1 a week. The importance of this gate is indicated by the wages paid to the Collectors at the other gates which were at most 7s (£0.35) and in a number of cases 3s (0.15) or 2s (£0.1) per week. The siting of this gate at Withdean was, however, to split the Trustees into two factions. The Brighton area Trustees were anxious to place the gate further north, beyond Patcham village, to avoid the same problem in the future. Another faction representing the Trustees at the northern end of the Road, anxious to maximise revenue, wanted the gate to stay at Withdean. Following an acrimonious meeting at Brighton on 18

January 1855, rival special meetings were called at both Haywards Heath on 5 February and Brighton Town Hall on 8 February. Because of the dissention, orders were given not to continue with the building of a permanent tollhouse at Withdean. A compromise agreement was arrived at, which ordered the temporary tollhouse at Withdean to be moved to Patcham and to remain there until 3 December 1856. This would enable a comparison to be made between the takings collected at Withdean with those at Patcham. In return it was agreed that future meetings would be held alternately at the Station Hotel, Haywards Heath and the Town Hall Brighton and consideration would be given to removing the South Crawley toll gate. Ultimately the Brighton faction were the victors. After October 1859 all meetings were held at Brighton, the South Crawley toll remained, and by April 1857 a decision had been made to establish the toll gate permanently at Patcham. The former Withdean tollhouse was sold to the “Trustees of the Lindfield Roads” (Newchapel and Brighton Trustees) for £15. Why they wanted this and where it was used is unclear²⁵.

No illustrations of the Withdean tollhouse exist but it appears to have been a temporary structure, possibly of timber, which enabled it to be moved easily from one location to another.



Fig. 4 Patcham tollhouse c.1910

Patcham TQ 299092

At a special meeting of the Trustees at Brighton Town Hall in March 1855 it was finally resolved to move the collection of tolls to Patcham where the temporary toll house and gate and side bars were to be erected “at the north end of Col. Paine’s wall” (i.e., the north wall of the grounds of Patcham Place). This would be effective from 31 March 1855²⁶. The position chosen for the permanent tollhouse was on the west side of the road

immediately north of the crossroads to Waterhall Road. Photographic evidence (fig. 4) shows the tollhouse to be a stuccoed bungalow of three bays, the front to the road having a central doorway flanked by windows, the northerly and largest of which projected with canted side lights. The roof was slated and two chimney stacks existed. The ground plan was rectangular with a rectangular projection at the rear. The cottage was built on land belonging to the Marquis of Abergavenny who had an option to recover it should it no longer be required by the Trust. When the Trust was wound up, the cottage was purchased on 30 November by the Abergavenny Estate for £20, the value of the building only²⁷. The 1881 census shows that it was occupied by William Dodd aged 48, a shepherd, his wife and six sons, two of whom were also shepherds. By the 1930s it had ceased to be used as a dwelling and was utilised as a mortuary. It was finally demolished in 1934.

Stonepound TQ 299156

The Clayton title award shows the gate across the Brighton and Lovell Heath Turnpike on the east side of the road immediately south of the crossroads where the A273 intersects with the line of the Crouch Hill, Henfield and Ditchling Trust (B2116). The tollhouse is not included in the property schedules however. It appears to have projected into the road and probably had little or no garden²⁸. When the Trust was about to be wound up the Clerk to the Trustees wrote to Clayton Parish Council to see if it required the tollhouse to be "pulled down and thrown into the road". The Parish replied that it wanted a portion of the house demolished, but sufficient remained for the Trustees to order what remained to be valued for sale. A purchaser was found in December 1876, when William Champion of Danny Park, Hurstpierpoint paid £10 for "all that piece or parcel of land heretofore forming part of the site of Stone Pound Tollhouse"²⁹. The low purchase price might suggest that the tollhouse had already been completely demolished by this date. Tolls at this gate were being farmed as early as 1806 and this practice continued for many years. Charles Harper in his Brighton Road (3rd edn 1922) states that it was at Stonepound that the London mail coach was delayed in the great Christmas Eve snowstorm of 1836.

St John's Common TQ 309210

Situated half a mile north of the bottom of Fairplace Hill, Burgess Hill on the A273 (Isaacs Lane) on the

east side of the road and shown built into the road. This sealed its fate in October 1876, for Clayton Parish Council required its demolition as it obstructed the traffic. Tolls were collected here from 1807. No illustrations are known³⁰.

Slough Green TQ 284260

Situated at the junction of the B2114 road from Cuckfield to Handcross and the B2115 leading through Warninglid to the A279 Lower Beeding to Handcross road. Maps of 1824 and 1843 show the tollhouse on an island site with gates across both of the roads³¹. The gate was of some importance and was farmed with the Crawley gates for £1,960 in 1811. It probably operated throughout the life of the Trust. When the Trust was wound up it was sold to Captain Dearden of Nymans for £75³². No illustrations of the house are known and it may have been demolished soon after the termination of the Trust.

Bigges Farm TQ 284272

Also referred to as Holmstead Hill and situated just to the north of Slough Green. A side bar was erected across a lane running eastwards from the B2114 which with another lane to Mizbrook's Farm could have been used to avoid the toll at Slough Green. A cottage was provided for the collector on the north of the side lane at its junction with the B2114, on a plot 1 perch in extent. The revenue collected must have been small and in November 1854 Thomas Holden, the collector, received no remuneration except the tolls collected³³.

Handcross TQ 263301

Situated on the east side of Handcross High Street at the north end, just south of the point where the B2110 branches off to Turners Hill. The single gate was across the Turnpike (B2114) with no side gate. The cottage was on a substantial plot of 14 perches. When the Trust was wound up the cottage and site was sold in December 1876 to Rev. John Howeis of Slaugham for £75. Early in the following year it was used as an isolation hospital for smallpox victims. Shortly after this a working men's club was built on the site, opening in 1878. This was still operative in 1929 but before World War II was converted into two cottages named "The Old Clubhouse" and "Tollgate Cottage"³⁴.

Pease Pottage TQ 260332

A plan of The Brighton to Lovell Heath Trust dated 28 November 1836 shows a gate at Pease Pottage

across the road to Horsham³⁵. This appears to have existed as early as May 1788 when it was mentioned in connection with a robbery effected by two footpads, and as late as 1892 Charles Harper records a gate "that spanned the Horsham road, the gate has been latterly dropped"³⁶. No mention of a side bar appears in any of the documents referring to the Turnpike and it seems unlikely that turnpike road tolls were collected here.

Ifield Bar TQ 266358

This was situated on the west side of the old alignment of the A23 just to the north of Hogshill Farm. It was farmed by the Trust as early as 1806 and may have existed some time before this. Its removal was considered, but not implemented, in 1854, by which time it was being described as Crawley South and the wages of the keeper, John Andrew, were 7s (£0.35), the same rate as that given to the main gates. When the Trust was wound up in 1876, Ifield parish indicated that they wished the house to be pulled down and the site incorporated in the road. Not all the plot was required for road widening and the remainder of the land and the building materials from the house were sold to a John Wright for £20³⁷.



Fig. 5 Crawley tollhouse c.1910

Crawley TQ 269372

This tollhouse is sometimes referred to as Crawley Northgate. It was situated on the west side of the old A23 immediately to the north of the Rising Sun Inn at the north end of the town. It occupied a plot 1 rod 1 perch in extent. A photograph taken about 1910 (fig. 5) shows a two-storey cottage, brick to the ground floor and tile-hung above. It had a tiled roof and was stated to contain four rooms. The road frontage had a door protected by a porch and a single window on the ground floor and another window at first-floor level. A single-storey extension

was provided to the north and the north end of a cottage had near the apex of the roof a painted sign reading "CRAWLEY". The house was demolished shortly after the taking of the photograph. The gate probably dates from the setting up of the Trust and tolls are recorded being collected here in 1801. When the powers of the Trust ended the cottage was sold to the Rev. Matthew Buckle of Elsington Vicarage, Northumberland for £115, after an offer of £100 from the same source had been declined³⁸.

Anstye TQ 291232

At Anstye Cross, the junction of the A272 and B2036 roads, the tollhouse being in the fork of the two roads with side bars across both. This gate was not part of the 1824 scheme for the branch to West Grinstead and tolls were being collected here as early as 1806. At the foot of Fairplace Hill, Burgess Hill travellers wishing to proceed north had a choice of roads to take them on to Cuckfield. The Turnpike forked right using the A273, and without the gate at Anstye travellers using the B2036 could avoid the tollgate at St. John's Common on the other road. This probably explains why the Anstye bars were set up. In 1876 when the Trust's powers expired, the parish of Cuckfield demanded that the tollhouse be demolished and the site incorporated in the road, and this was implemented³⁹. A garage opposite the tollhouse site trades as "Toll House Garage".

THE WEST GRINSTEAD BRANCH

Although the branch was only 12 miles in length it was well provided with gates to ensure that traffic fed off other turnpikes that it crossed contributed income.

Bolney (Cross Posts) Gate TQ 257224

Situated at the point where the A272 is crossed by a minor road (Foxhall Lane) connecting Warninglid with Twineham. The house stood at the north-west corner of the crossroads with a gate across the turnpike (A272). The cottage was sold in November 1876 to Henry Martin of Hurstpierpoint for £60 and survived until its demolition about 1962 (fig. 6). In October 1937 it was stated to have been recently restored and "picturesque with nasturtiums clustered round the walls and road verges". A number of photographs exist which show it to have been cement rendered, about 25 ft × 20 ft, with a tiled roof. A projecting window and door occupied the entire frontage to the A272 and the single chimney stack was singularly shaped like a letter "Z". A lean-

to extension existed to the west, probably of later date. The plot on which the tollhouse stood was five perches in extent⁴⁰.



Fig. 6 Bolney (Crosspost) tollhouse Oct 1937

Oakendean Gate TQ 232227

At the crossroads where a lane from Warninglid to Twineham crosses the A272 with gates across both the turnpike and the lane towards Twineham. The house was situated at the south-west corner of the intersection on a plot of six perches. It was only about two miles from the Bolney gate and it would seem that the Trust felt it necessary to have both gates to intercept traffic trying to divert on to minor roads to evade toll. On the expiry of the Trust the tollhouse was sold to George Norton of 2 Gloucester Place, Hyde Park, London for £60⁴¹.

West Grinstead (Champions Gate) TQ 191227

At the crossroads where the A272 is crossed by lanes leading north to Maplehurst and south to Partridge Green. The tollhouse was at the south-west of the intersection on a plot of nine perches. At the expiry of the Trust it was sold to the Rev. John Goring of Wiston for £50. The tollhouse was reported as being derelict some time before 1923 when a new cottage was built on the plot⁴². Frank Gregory noted on 24 October 1937 that it had gone without trace. A photograph described as West Grinstead tollhouse was published in August 1939⁴³. A comparison of this with photographs of Bolney (Cross Posts) show the two to be identical. The published image stated to be West Grinstead tollhouse must therefore be considered as suspect and is probably an incorrect identification of the one at Bolney.

Buck Barn TQ 166228

This must be one of the last tollgates erected in Sussex. The resolution to establish the gate was passed by the Trustees at their meeting of 27 October 1860. The first edition 25" OS map of 1875 shows only a gate with no adjacent cottage despite the fact that in October 1876 this location was included in a list of the other tollhouse sites to be valued prior to sale on the winding up of the trust. The reason for this gate must be the opening of West Grinstead station on the Horsham to Shoreham line in September 1861. Without the gate, passengers coming from the west to travel by train would not have paid any toll to the Trust⁴⁴.

Milestones

None are now in place along the main line of the road or the West Grinstead branch. They are however shown along the line of the Trust in Ordnance Survey maps of the 1930s though from Burgess Hill the road to Anstye Cross, never part of the Trust, has them in place and none are shown along Isaac's Lane or the A272. These may therefore date from the period following the demise of the Trust.

Newchapel and Brighton Trust 1770

One of the first turnpikes to cross into Sussex was the City of London to East Grinstead Trust of 1717, which opened initially to Highgate on the edge of Ashdown Forest just south of Forest Row. In 1770 a new turnpike was authorised leaving the East Grinstead line (the present A22) at Newchapel in Surrey⁴⁵. This new turnpike followed the line of the present B2028 to Turners Hill and south to Lindfield and then the B2112 to Ditchling. The initial terminus of the Trust was at Ditchling Bost Hills (Ditchling Beacon), and the remainder of the route to Brighton, over the Downs, was over well-drained chalk and not requiring the attention of the turnpike. It was not until 1808 that the remaining few miles of road to Brighton were added⁴⁶. As a through route to Brighton from London it had certain disadvantages. It was not only longer than the turnpike roads through Cuckfield or Lewes, opened in the same year, but also suffered from the steep ascent of the Downs south of Ditchling village. Intermediate traffic was limited. Lindfield was the largest settlement with a population of 1,485 in 1831 and maintaining annual fairs for sheep and cattle in April and May and lambs in August. Ditchling was

smaller with only 917 inhabitants in 1831 and with only one annual fair for sheep in April⁴⁷. The volume of both local and through traffic was therefore restricted. Coach proprietors tended to avoid the road though in 1793 Whichelo & Co. were operating a service to London three times weekly⁴⁸. By the beginning of the nineteenth century speed and regularity were important to attracting the patronage of the growing coaching traffic, and here the Newchapel and Brighton Trust were at a disadvantage. Plans were prepared for major works costing £20,000 which involved excavating a tunnel 1,500 feet in length from the top of the Downs above Ditchling to ease the gradient, and a new section of road north of Wivelsfield to Lindfield to avoid the elevated section across Haywards Heath. Nothing came of the project⁴⁹. Although initially proposed in 1824, it was not until 1830 when the Trust applied for powers to build a new line of road from south of Ditchling village to the foot of Clayton Hill, 1 mile and 7 furlongs in length that action was taken⁵⁰. The Trust was now 26 miles and 2 furlongs in length and maintained 14 toll bars. The new line of 1830 meant that the Trust had effectively abandoned hope of attracting through traffic across Ditchling Beacon and accepted the need to feed traffic on to the rival Brighton and Lovell Heath turnpike.

Financially the main line of the Trust appears to have been able to cover its costs. In the year to 29 September 1829 its toll revenue amounted to £832 14s (£832.70) to which was added £124 19s (£124.95) from the parishes in lieu of statute labour. Its total income of £1,046 16s 8d (£1,046.84) was matched by an expenditure of £997 2s 8d (£997.14) and the Trust's accumulated debt was £9,170 3s 8d (£9,170.19). Railway competition did not directly affect the line of road and traffic seeking to reach railway stations might be financially rewarding, such as traffic from Lindfield to Haywards Heath station. The short branch from Ditchling to Clayton maintained separate accounts and was not in all years able to pay interest on its mortgage debt. In 1852 it was eight years in arrears. The Trust continued to function until 1 November 1884⁵¹.

Tollhouses

Parliamentary returns in 1829 list 13 gates and those of 1840 and 1852 14 bars including two on the Ditchling to Clayton branch.

Foggett Heath TQ 362423

A Surrey tollhouse, on the north side of the B2028

about 500 feet west of the intersection of this road by the A22, from Godstone to East Grinstead. The house was situated at the west end of a garden plot with a gate across the B2028. It did not long survive the closure of the Trust and is not shown on the 1912 edition of the Ordnance Survey.

West Park TQ 343410

A pair of semi-detached cottages of late-nineteenth century date exist named 'Tollgate Cottages' with a wooden shed with a low pitched slate roof to the rear. This is the site of a tollhouse shown on a deposited plan of 1824 but it seems unlikely that this structure survives. The gate is in Surrey⁵².

Wallage TQ 341370

Shown on the 1824 deposited plan on the east side of the B2028 just before the turning to Rowfant, but demolished by January 1843 when the plot of land "adjoining the site of the former Turnpike House called Wallage Gate at the southern extremity of Crawley Down" was conveyed to a John Fuller of Worth, wheelwright⁵³. In 1977 it was stated that the boundaries of the toll cottage grounds were still in existence⁵².

Wallage Lane TQ 340368

Referred to as Wallage (double) gate and presumably had gates across both the Turnpike (B2028) and the road to Rowfant. The tollhouse was situated on the west side of the turnpike, to the south of the road to Rowfant. It was clearly a replacement for the former Wallage gate. In January 1884 the garden plot of Wallage Lane tollhouse was sold to Sir Curtis Miranda Lampson of Rowfant for £15 and the transaction involved only "land adjoining toll house now demolished"⁵⁴.

The tollhouse sites in the Crawley Down area is further complicated by a house at TQ 338381 named 'Tollgate Cottage'. No tollgate is shown here on the 1840 Worth title award map, though a cottage is shown at this location on the 1875 6" OS map. The existing cottage on the site is relatively modern and evidence that tolls were collected here rest solely on the recollections of a lady born in Wallage Lane toll cottage in 1850 and reported by Jeremy Hodkinson of Crawley Down in 1977. Its closeness to Wallage Lane gate makes it an unlikely candidate.

Turners Hill TQ 341356

Two gates existed at the intersection of the B2028 with the B2110 in the centre of the village. One

controlled the traffic along the turnpike; the other was a side bar across the road leading westwards (now Church Road) to Worth and Crawley. The toll cottage was on the north side of the road at the junction on a site of four perches, though not shown as owned by the Trust⁵⁵.

Hapstead Green TQ 348294

The tollhouse was situated at the junction of the B2028 and College Lane at the southern entrance to Ardingly village, with gates across both roads. The toll cottage was on the west side of the turnpike road immediately before the junction. The plot of land was one perch in extent and in 1840 the gatekeeper was Peter Box. In November 1884 it was sold to the Hon. William Hill of Wakehurst for £20. The tollhouse survived for some years and in October 1938 Frank Gregory noted that a small tree and an oak seat were placed here, the seat bearing the inscription "This seat and tree mark the site of the Toll House demolished in 1923"⁵⁶.

Lindfield TQ 347256

At least three different photographs of late-nineteenth century date show Lindfield Gate, two of which have been previously published. They show the gate standing in front of a timber-framed two-storey house which stood on the east side of the High Street (fig. 7). This has long been identified as the tollhouse and still exists. The tithe award schedules for 1845 however show the owner of this property as a John Copeland with George Nye as the occupant. The Trust does not appear to have owned the property, though George Nye may have collected the tolls as an employee of the Trust. It is significant that in the list of tollhouses for sale, drawn up in November 1884, Lindfield is not included. In February 1803 the *Sussex Weekly Advertiser* gave the news that a new gate was to be erected at the junction of Hickmans Lane and the



Fig. 7 Lindfield tollgate c.1880



Fig. 8 Lindfield side bar across Hickmans Lane c.1860

High Street, and it can be surmised that this lane was providing a means of avoiding paying the toll at the main Lindfield gate. A drawing of c.1860 (fig. 8) shows this gate beside a High Street property known as "Barnlands" on the south side of the lane. As it was some distance from the main gate it would have required a separate collector of tolls. The gatekeeper appears to have lived in the corner shop flanking the north side of the lane. This building also faced the High Street and was at one time occupied by a Mr Featherstone, a clock and watch maker.

The citizens of Lindfield appear initially to have tolerated these gates but the opening of Haywards Heath station in 1841 changed the attitude of those living north of the gate. In 1861 the Lindfield vestry sought to have the gate removed. A petition was drawn up and sent to Sir George Lewis, the Secretary of State for the Home Department, but was unsuccessful. It was not until the Trust was abolished on 1 November 1884 that the citizens of the village were able to cast aside the gates and railings which conveniently provided fuel for the bonfires in the High Street four days later to celebrate the thwarting of the Gunpowder Plot of 1605⁵⁷.

Clevewater TQ 337219

Situated on the west side of the turnpike where the car park of the Fox and Hounds public house now exists, immediately to the south of the junction of Hurstwood Lane with the B2112. A gate existed across the turnpike but not across Hurstwood Lane. The house was on a plot of 36 perches belonging to the road trust. The tollhouse was pulled down when the trust expired in November 1884 and the land was sold for £50⁵⁸.

Between Clevewater and Ditchling there were gates across the road at the entrance to and exit from

Ditchling Common, and on side roads feeding onto the Common from Plumpton Green and Burgess Hill. These were to prevent animals straying but have mistakenly been identified as toll gates⁵⁹.

Ditchling TQ 326154

The tollhouse was situated just north of the former North Star Inn on the west side of the road occupying a small plot of one perch. The tollhouse was sold in November 1884 to Mintar Martin of Brighton and was still in existence in 1908⁶⁰. A Regency villa now called 'Gate House' exists near the site.

Ditchling South TQ 327147

The tollhouse was south of the village on the east side of the road leading towards Ditchling Beacon, with a garden plot on the west of the road, amounting in all to nine perches. At this point, formerly, a road branched off to the west, extending to Lodge Lane, Keymer, the only westerly road from Ditchling when the Trust was formed. A two-storey cottage, 23 Beacon Road, called 'Paygate Cottage', exists at this point. In October 1937, when Frank Gregory photographed the cottage, he referred to it as a "two-storey cottage, tiled sides and roof, half-tiled front, with a small window known as South Gate". The cottage in its present form appears to be of early-nineteenth century date but has been considerably altered over the years. It was purchased on 20 November 1884 by the Marquis of Abergavenny for £20⁶¹.

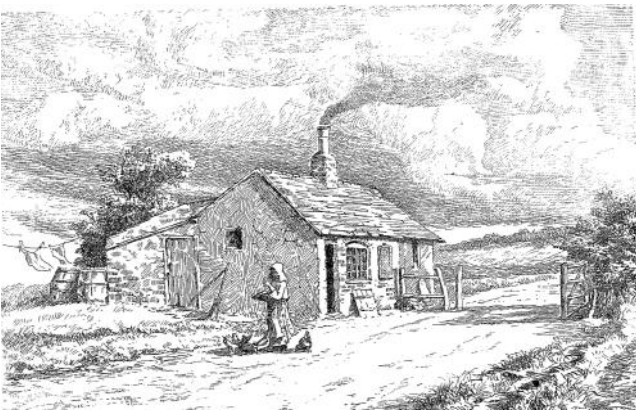

Fig. 9 Hill House tollhouse, Ditchling Road, Brighton 1892

Hill House TQ 315079

Situated on the border between Patcham and Preston parishes on the west side of Ditchling Road. In order to improve the revenue from this gate, the Trustees proposed in 1824 to resite it nearer Brighton. This was vigorously opposed at the

Brighton vestry meeting in April of that year where they described such a move as illegal and "injurious to the Town by interfering with and taxing the customary rides ... to the Downs". No move was made. In November 1884 the tollhouse and garden plot was sold jointly to Sir Edward Cholmelly Dering of Surrenden Dering in Kent and George Edward Dering of 1, Brick Court, Temple, London for £35. The house survived and was sketched in 1892 by Walter Puttick. Already by this date it appears to have been extended by one bay to the north and had an outbuilding to the rear compared with its appearance on the 1842 tithe map⁶².

Keymer Lodge TQ 314145

The only gate on the 1830 Ditchling to Clayton branch. It was on the south side of the road (B2112), immediately west of the point where Lodge Lane branched north and another road south, to connect with a lane running along the foot of the Downs. The tollhouse was on a plot of land three perches in extent. The land and house was sold in November 1884 to William Henry Champion of Danny Park, Hurstpierpoint. A two-storey cottage (Lodge Cottage), probably of late-nineteenth century date, stands on the site close to the road, but is unlikely to incorporate anything from the old tollhouse⁶³.

Milestones

None were located.

The Henfield Trust 1777

The year 1770 had seen three separate turnpikes leading to Brighton via Crawley, Ditchling and Lewes. Six years later a further Act (17 Geo III c90) allowed the turnpiking of the road between Henfield and Brighton providing a more westerly route to London avoiding the steep ascents of the Downs at Clayton and Ditchling. This new turnpike, nine miles in extent, followed the line of the A281 from Henfield through Woodmancote and then skirting the west flank of Newtimber Hill, struck south through the gap at Sedlescombe to Brighton over, what are now, unclassified roads, entering Brighton down the present Dyke Road. The Trust also maintained a branch road from the A281 extending north to the B2116 at High Cross and north again for two furlongs towards the village of Twineham. In 1798 when a renewal Act was passed (38 Geo III c53), this branch was extended by a further 1 mile and 8 furlongs, reaching Herrings Clappers, just short of Twineham village.

As a through route to London, this road appears to have attracted only limited patronage. Its attraction was that it tapped intermediate traffic from Henfield and Horsham and was a more easily graded route, but at 56 miles it was 2 miles longer than the route through Cuckfield. Crawford's Brighton guide of 1788 lists a light coach to London, three days a week by this road, but also lists a service to London by way of Shoreham and Horsham on another three days. This service appears to have been operating on a similar basis in 1800⁶⁴. The opening of the route by way of the Dale Gap in 1808, and the extension of the Horsham to Steyning Turnpike to Shoreham in 1807 would have seriously reduced the attraction of the Sedlescombe gap route for London traffic. Local traffic from Brighton would have continued, as a branch road from the turnpike led to the Devil's Dyke, a tourist attraction which featured in Brighton guides from the 1780s. Unfortunately the Trust had no gates between Brighton and Poynings and could not benefit from this traffic though it had to bear the cost of the road maintenance. The trustees attempted to rectify this situation in 1816 by erecting a gate nearer Brighton but predictably it aroused serious opposition from the inhabitants of, and visitors to, Brighton. Fortunately for the Brighton Vestry, which was voicing the opposition, the Trust needed to renew its powers by parliamentary Act in 1817, which contained a clause to increase toll charges. Brighton opposition to the new Act was bought off by a compromise agreement. The trustees offered to abandon the road from the top of Sedlescombe Hill to Brighton, which would revert to parish maintenance. The Vestry in return agreed not to oppose the Act provided the new toll charges were "fair and equitable" and the Trust did not reserve any powers to renew control over the abandoned road or erect any gate⁶⁵. From this date the Trust was reliant on traffic fed off the Pyecombe and Hickstead Trust (A23), now the preferred route to London from Brighton, that wished to proceed towards Henfield and Horsham (A281). Also abandoned was a short branch from the foot of Newtimber Hill to Newtimber village which was now largely redundant as the village could be served from the Pyecombe and Hickstead Trust road. The Trust had its powers renewed four times by parliamentary Act in Victoria's reign and eventually expired on 31 December 1876.

The income of the Trust was never large. At the Terry's Cross Gate in the quarter from Michaelmas 1788 tolls amounted to £26 13s (£26.65) and fell in the

two following quarters to £16 18s (£26.90) and £10 8s (£10.40) respectively, reflecting the lower traffic in the winter months. The gatekeeper, William Holman, received wages of £5 4s (£5.20) for the quarter to Michaelmas 1788. Subsequent to the abandonment of the road south of Poynings, tolls on the remaining sections were entirely adequate to meet expenses and pay the mortgagees the annual 4% interest due. In 1829 toll income amounted to £432, and the collection of contributions from parishes towards road maintenance, which in the quarter to Lady Day 1789 had amounted to £48 12s (£48.60), had been abandoned. Expenditure in 1829 was £347 3s 4d (£347.17) and the Trust was indebted to its mortgagees for £3,286 3s 2d (£3,286.16). Railway competition may have reduced income, though most of the traffic on the Trust by this date was local, and direct competition came late with the opening of the Shoreham to Horsham line in July 1861. In 1851 the Trust was still able to pay the 4% due to the mortgagees amounting to £133 19s 6d (£133.98) and had already paid £178 16s 10d (£178.84) off its accumulated debts⁶⁶.

Tollhouses

A parliamentary return of 1829 declared four gates on the Trust, but the number shown in both 1840 and 1852 were three gates⁶⁷. One included in 1829 may have been the side gate at Poynings.

Terry's Cross TQ 235147

Situated in Woodmancote parish on the south side of the A281 on a plot of eight perches⁶⁸. To its immediate left was a minor road leading to Bramlands. The tollhouse does not survive and no illustrations have been located.

High Cross TQ 251174

On the branch towards Twineham, north of the Crouch Hill (Henfield) to Ditchling Trust road (B2116) and on the east side immediately north of the point at which a minor road branches right to Sayers Common. The tollhouse was in Albourne parish on a plot of seven perches. Toll revenue was sparse with only £5 15s (£5.75) taken between Christmas and Lady Day 1789 and £1 3s (£1.15) from Lady Day to mid-summer 1791. The tollhouse does not survive and no illustrations of it are known⁶⁹.

Poynings TQ 266122

The tollhouse was on the west side of the turnpike at a point where a road branches to the west to Poynings village. The tollhouse was in Newtimber

parish and built on a substantial plot of 31 perches used as a garden. Apart from the main gates across the turnpike there was a side gate on the road to Poynings village. John Sayers was the keeper in 1840. It was a profitable gate with a revenue of £29 2s (£29.10) in the quarter to Michaelmas 1788 and from then to Christmas £22 1s (£22.05). In 1790 toll revenue from this gate was £26 4s 8½d (£26.24) from Lady Day to Mid-summer and £27 17s 6d (£27.87) for the next quarter. In the winter months receipts were lower and £10 10s (£10.50) was taken between Christmas and Lady Day 1789 and £11 16s 9d (£11.84) in the same quarter in 1791⁷⁰.

Frank Gregory visited the site on 30 October 1937 and talked to Poynings residents including a Mrs Pollard who was the granddaughter of Mr J. Barham who was the toll collector and lived in the house for between 40 and 50 years in all. He evidently was allowed to stay on after the Trust was wound up until his death in 1898, which was said to have been occasioned by the shock of learning that the cottage had been condemned and would have to be demolished. Frank was shown a photograph and also a drawing of the tollhouse by Mrs Pollard and he described the building as being a “small wooden building with windows facing north and south with a tiled roof and a single chimney”. At the time of his visit Frank confirmed that the site of the cottage was then part of the road, the corner between the Poynings and Sedlescombe roads having been cut away. The garden was still being used as an allotment. The whereabouts of the photograph and drawing shown to Frank are not known and no other illustrations have been located⁷¹.

Milestones

None located, though they are marked on the 1840 tithe award map for Newtimber and the 1843 map for Poynings.

Between 1770 and 1777 four lines of turnpike had been developed providing different routes by which Brighton could be accessed from the capital. For the next thirty years there was no further development, but in the first decade of the nineteenth century two further trusts opened to improve access to the town. This renewed turnpike development reflected a number of factors:

1. The continuing growth of Brighton as a fashionable resort patronised by an expanding range of persons from the affluent middle classes benefitting from the expansion of industry, trade

and professional services to royalty in the form of the Prince of Wales. Census records indicate that between 1801 and 1811 there was an increase in house building, the number of dwellings rising from 1,420 to 2,380. This expansion was to continue apace in the following decades.

2. The fierce competition that was developing amongst coach proprietors operating between the capital and Brighton. By 1818 there were 13 daily departures daily for London increasing to 15 in the season. By 1822 the total number of departures had risen to 21⁷². To attract passengers, more comfortable, safer and larger vehicles were being introduced, but competition could also be on the ability to cut journey time.

3. There was a growing professionalism amongst road surveyors and improved techniques of road construction and maintenance. No longer were turnpike promoters and surveyors just prepared to adopt and improve existing parish roads. Now new lines of road were being developed where none existed before, providing more direct routes and easier gradients. Road surveyors were willing to tackle routes through clay lowlands which earlier would have been avoided in favour of better drained upland routes. The names of these new professionals are in most cases little known, but typical of the breed was the Collis family in Kent, one of whom was reported in 1819 by William Horne, the mail and stage coach proprietor, starting work on the Brighton road⁷³.

In Sussex, two Trusts reflected this trend:

- The Pyecombe and Hickstead Trust 1808
- The Horley and Cuckfield Trust 1809

Both of these roads were built to compete directly with existing lines of road and ran parallel to them. They provided better graded and more direct routes and avoided one or both of the existing coaching towns such as Cuckfield and Crawley.

The Pyecombe and Hickstead Trust 1808

This Trust developed a line of road, incorporating parts of existing turnpikes but also constructing considerable stretches of entirely new road. It commenced at Pyecombe where it departed from the line of the Brighton and Lovell Heath Trust, and then thrust north through the Dale Gap in the South Downs, taking over part of the existing Henfield Trust. This avoided the ascent of the South Downs at Clayton Hill on the existing turnpike. It

continued its course north incorporating a branch of the Crouch Hill (Henfield) to Ditchling Trust which had from 1798 connected Ubleys Farm, Albourne with the village of Newtimber. Compensation was paid to the two trusts who had surrendered sections of their road. North of Albourne it was largely a new line of road and initially re-connected with the Brighton and Lovell Heath Turnpike at Staplefield Common. In 1823 however a further section of new road was built to carry the junction further north to Handcross saving in distance a further 3 furlongs and 9 perches. The Pyecombe and Hickstead Turnpike is now the A23 road, if recent bypass roads avoiding Sayers Common are ignored. In length the turnpike was 12 miles 6 furlongs and 22 yards. Not only was the road shorter and more evenly graded but it avoided the market town of Cuckfield. The inhabitants of Cuckfield opposed to the new road because of their existing coaching interests, but they were ineffective in stopping it. By taking over a section of the Henfield Trust road, the new turnpike acquired a short branch of 7 furlongs and 12 perches connecting their road with Newtimber and Poynings Common⁷⁴.

Financially the Trust had a mixed history. The building of a substantially new line of road to high standards created a substantial debt burden, but initially the volume of traffic brought in sufficient income to pay the interest on the debt and maintain the road to the standard required to attract the through traffic to Brighton. This situation continued through to the 1830s and in 1829 the income of £2,313 0s 9d (£2313.04) fully covered the expenditure of £2,217 3s 2d (£2,217.16). By the mid 1830s however the railway threat was considered sufficiently serious for plans to be drawn up in November 1836 for the laying of stone blocks along the side of the London to Brighton road to take the weight of possible steam road carriages⁷⁵. These vehicles and the surface to carry them did not materialise, but the railway did, and was opened throughout by 1841. Coach services to London were immediately withdrawn, being unable to compete either in terms of fares charged or speed. This completely altered the finances of the Trust. In 1837 income had amounted to £2,619 2s 2d (£2619.11) providing a surplus after costs had been met of £341 5s 6d (£341.27) and as late as 1840 similar figures of £2,606 14s 2d (£2,606.71) income and £2,318 9s 6d (£2318.47) were being recorded. By 1842 however income had collapsed to £547 9s 2d (£547.46) and the holders of the mortgages had exercised their right to

seize the gates and apply the income as they thought fit. The unpaid capital debt amounted to £13,699 10s (£13,699.50). There was only one way to try to address the problem and that was to drastically cut the cost of road maintenance and the quality of the road. As the road was carrying little through traffic to London, local traffic did not require the same quality of road surface. One thing was not initially sacrificed and that was the interest due to the mortgage holders. In January 1844 John Hamlin Borrer, 'Mortgagee in Possession' was still paying the interest of 5% pa. due. The gates were in the hands of the mortgagees in 1850 and no attempts were being made to reduce the capital debt despite the fact that income had fallen to £353 0s 11d (£353.04) by 1851. At this date if the whole of the income had been applied to paying the mortgagees they would only have received just over 2.5%, or roughly half that due. If it had been wholly used to pay off the debt it would have taken 44 years. The Trust struggled on however until its final demise on 1 November 1886 (36 & 37 Vict. C90)⁷⁶.

Tollhouses

A parliamentary return in 1829 showed four gates and two sidebars, one gate being on the branch road to Poynings (possibly a sidebar). An 1852 return listed seven bars, which would have included sidebars.



Fig. 10 Dale tollhouse (Brian Stevens collection)

Dale TQ 280129

In Pyecombe parish and situated on a triangular plot of 31 perches between the Pyecombe and Hickstead Trust (A23) and the Henfield Trust (A281). It was a single-storey cottage set back from the junction facing south, and was later extended both to the north and the west (fig. 10). The tollhouse seems to have survived until the mid 1930s when it was

demolished to improve the road junction. Frank Gregory visited the site on 30 October 1937 and noted “bricks, tiles and rubble” on the plot and also “flowers belonging to the side garden still growing in places” and the “vegetable garden still standing there”⁷⁷.

Muddleswood TQ 269150

One of two gates at this location, the other being on the branch of the Crouch Hill (Henfield) and Ditchling Trust from Hurstpierpoint to Poynings Common (B2177). The Hickstead Trust house was on a plot of four perches on the east side of the former A23 north of the original junction of the Poynings Common branch. The gatekeeper in 1840 was James Hutton. Nothing remains of the tollhouse and no illustrations have been located⁷⁸.



Fig. 11 Hickstead tollhouse c.1975

Hickstead TQ 269203

The gate at this location appears to have had a complex history. A deposited plan dated 30 September 1807 shows no gate at this point, but it is clearly marked on another map of 1824. The Castle Inn is shown on the west side of the turnpike immediately north of the crossroads and a gate is marked across the road immediately to the south of the crossroads. A further plan dated 28 November 1836 shows the gate across the turnpike north of the crossroads but the Twineham tithe award map of the following year shows no gates at this location. The 1875 25-inch OS map however shows the Castle Inn to the south-west of the crossroads, no gate across the turnpike but side gates across both the roads to Twineham and Goddards Green. In the absence of the records of this Trust it is difficult to provide an explanation of the discrepancies. All that can be said is that the Trust maintained a gate or gates at this location throughout. One building

survives that may be relevant to the collection of tolls at this point. This is a two-storey house, flint with brick quoins, with weather-boarded (now tiled) upper storey and a slate roof (fig. 11). This is to the south of the crossroads and on the west of the turnpike, the position of the tollhouse on the 1824 map. The cottage has a small side window near the front, of a type often found in tollhouses. It has more recent additions both north and south and the road at this point has been realigned, so that it stands back from the edge of the present road. A Victorian post box has been let into the centre of the house front, a survivor from the days when it was a stores and post office. A further complication arises from the fact that the Castle Inn appears to have been formerly called the New Inn.

The site was visited by Frank Gregory who comments on the location of the Hickstead side gate on the north west corner of the crossroads opposite the Hickstead Castle Inn, which appears to have relocated to the other side of the road. Quoting W. Simmons, then owner of the stores, he relates that the tollhouse was pulled down 25 to 30 years ago (c.1910) and that the site was the property of Miss Dawes of Hickstead Place. On the south side of the Twineham road is a house named Gate House. This may have originally been a pair of Victorian cottages converted to one. This reminder of one of the side bars which existed may have been built on the site occupied at one time by a tollhouse⁷⁹.

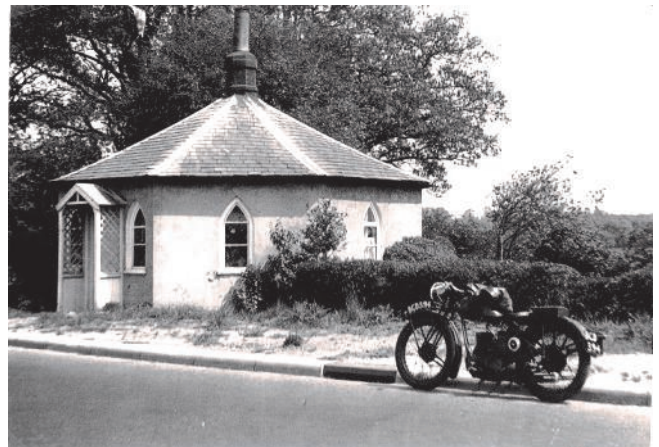

Fig. 12 Bolney tollhouse c.1940
(Sussex Archaeological Society)

Bolney TQ 265215

This was an octagonal building between Hickstead and Bolney crossroads on the east side of the road (fig. 12). Its location so close to Hickstead might suggest that it was a replacement for the gate there. Could it be that the Castle Inn, which would have

been associated with the provision of fresh coach horses, objected to the presence of a toll gate close to its premises? The Bolney gate does not appear on early surveys of the road but clearly was there at the date of the Bolney title award map of 1842 on a site of five perches. As it is not at a crossroads it had only a single gate across the turnpike. The house was stuccoed and the windows had gothic heads. The roof was slated and a single central chimney stack was provided and certainly by the 1930s it had a small wooden front porch with lattice sides. It was very much in the style of the *cottage ornée* so liked in the Regency period. The house was to survive in its original location until c1990 when alterations to the A23 obliged its demolition. It was however carefully taken down and re-erected as a lodge to Eastland Park, though without the porch. It is to be seen on the road from Warninglid village to Plummers Plain (B2114)⁸⁰.

Warninglid TQ 267259

Situated at Warninglid crossroads, where five roads met, on the south east side, with bars across the turnpike and across the road to Slough Green and Cuckfield. The plot was two perches in extent. The gate was also known as Pitt's Head. The tollhouse, as it protruded into the road, was demolished after the Trust was wound up, but the garden remained until the 1930s when the road was converted to a dual carriageway⁸¹.

No tollhouses were built on the extension of the Trust to Handcross.

Milestones

None now survive though they are shown on earlier ordnance survey maps.

The Horley and Cuckfield Trust 1809

This was an attempt to establish a fast coaching road starting at the Chequers Inn, north of Horley on the original line of the A23, bypassing Horley and Crawley and joining the Brighton and Lovell Heath Turnpike just north of Cuckfield at Whitemans Green. A study of Gardner and Gream's map of 1795 shows a number of minor roads serving the area, some of which were incorporated in part in the new line of road, but in many cases a parallel new line was built to effect improvements. The long stretch from Horley avoiding Worth is clearly indicative of the type of direct, evenly graded road that was envisaged, though the southern section

through Balcombe to Cuckfield, because of the terrain, has more pronounced gradients and is less direct⁸². This road, authorised by Act of Parliament in 1809 (49 Geo III c94), is now the B2036. It extended for a distance of 12 miles and 1 furlong.

As a more direct line for London to Brighton traffic it appears to have had limited success by the 1820s, with the "Royal George" stage coach service reported from 1822, and the "New Comet" by Auger & Co in 1823, and later the "True Blue". Local traffic must have been sparse as apart from the village of Balcombe, the road passed through a thinly populated part of the Weald. The Trust carried a heavy mortgage debt of £19,167 14s (£19,167.70) because of its ambitious construction and never generated the traffic to enable it to pay the interest due. Already by 1829 it was £13,000 in arrears with interest payments and had an additional floating debt of £3,000. Competition from the London to Brighton Railway after 1841 made the financial position considerably worse with income falling from £504 8s 6d (£504.47) in 1834 to £116 19s 6d (£116.97) in 1850. No interest had been paid to the mortgagees for 34 years and the Trust was effectively insolvent. Powers had been renewed in 1830 (1 Wm IV c42) but an attempt to renew them again was opposed by the Cuckfield Vestry. A motion was passed on 20 March 1862 and forwarded to the Secretary of State asking him not to renew the present Act or continue the trustee powers by a provisional order. This was successful and the *West Sussex Gazette* of 5 November 1863 reported the Trust insolvent. The toll gates were removed and future road maintenance passed to the parish authorities⁸³.

Tollhouses

The Trust recorded in parliamentary returns that it maintained four gates.

Horley TQ 290427

The gate was situated at the junction of Victoria Road with Balcombe Road. Nothing now remains and no illustrations have been located. The site is within the built-up area of Horley and the tollhouse may have been demolished at an early date⁸⁴.

Worth TQ 298393

Situated about a half a mile south of Black Corner where a minor road to Tinsley Green branches to the north-west. The tollhouse was on the east side of the road just to the south of the junction on a site of 1

acre 2 perches with a gate across the turnpike only. Nothing now remains and no illustrations have been located⁸⁵.

Norfolk Arms TQ 309331

This gate was also in the parish of Worth and to the south of the Norfolk Arms (now the Cowdray Arms) and the B2110 turn to East Grinstead. The tithe award map shows the tollhouse close to the junction on the east side of the road and it appears to have projected into the road. This would probably mean an immediate demolition when the Trust was wound up to 1863 and explains why no illustrations have been located⁸⁶.



Fig. 13 Cuckfield tollhouse c.1938

Cuckfield (Whitemans Green) TQ 304257

Close to the junction with the Brighton and Lovell Heath Trust at Whitemans Green. The tollhouse was situated on the northern side of the road with the gate across the Horley and Cuckfield Trust road only (fig. 13). The tollhouse was brick built and had a tiled roof with a single chimney stack. The frontage to the road was narrow with a central door only. All the windows were in the sides. The tollhouse was substantially enlarged to the back after it had been sold off by the Trust. It survived for many years and was demolished in the early 1970s⁸⁷.

A tollhouse has been reported as existing "on the corner of the road leading down to Worth Church". The Worth tithe award map of 1839-40 does not show a tollhouse at this location⁸⁸.

Milestones

None located.

Hurstpierpoint and Cuckfield Trust 1835

Controlled the road from the crossroads in the centre of Hurstpierpoint to Anstye Cross where a

junction was made with the Brighton and Lovell Heath Trust's West Grinstead branch. This was a distance of 4 miles and 37 poles. Its origins can be found in the branch road of the Crouch Hill (Henfield) to Ditchling Trust which was opened in 1834 from Hurstpierpoint to Poynings Common. This branch road connected with the Pyecombe and Hickstead Trust at Muddleswood. At this date this was the preferred route between London and Brighton. Some coach services were still using the earlier route of the Brighton and Lovell Heath Turnpike over Clayton Hill as they wished to serve and utilise the facilities of the market town of Cuckfield. A Dr Wheeler of Hurstpierpoint, who was one of the leading promoters of the branch to Poynings, saw advantage in building a new turnpike from the Hurstpierpoint end of the branch to Anstye, allowing coaching traffic both to take advantage of the valley route through the Dale Gap and also call at Cuckfield. He realised that facilities would have to be provided at Hurstpierpoint to service travellers and he therefore invested in a new coaching inn with stabling (The Lamb) still standing close to the crossroads where the turnpike commenced. An Act was passed in 1835 (5 & 6 Wm. IV c124) and, as befitted a line ambitious to attract coaching, it was built as a direct line of road, avoiding the twists and turns of the existing parish roads. This was only achieved by the expenditure of considerable sums on the new line of road. The anticipated traffic never materialised, as the supposed benefits were never sufficient to attract existing traffic from their established routes. A mere six years later the railway was open from London to Brighton and all hopes of success were finally ended. The Trust was left with considerable debts and a meagre income. In 1850 the debts were estimated to be £4,671 6s 6d (£4,671.32) and the toll income for that year was only £14 8s 6d (£14.42). There is evidence to suggest that part of the problem was insufficient funds initially to complete the project, for in 1840 it was reported that "The road is not yet in a perfect state of repair". When the Trust's powers were due to expire in 1856 they were renewed but only on an annual basis and they were finally terminated on 1 November 1867 (29-30 Vict. c105)⁸⁹.

Tollhouses

In a parliamentary return for 1840 it was stated that the Trust had two gates and in 1852 this was changed to two bars⁹¹.

Little Ease Gate TQ 288222

In the parish of Cuckfield just to the north of Leigh Manor and south of Brewhouse Pond on the west side of the road, which is now unclassified. No evidence exists on the site and no illustrations are known.

Anstye TQ 291232

A sidebar is shown across the Hurstpierpont and Cuckfield Trust just to the south of the junction on the 1843 Cuckfield tithe map, and it is possible that this was either under the control of the Trust or that they benefitted from tolls collected here by the Brighton and Lovell Heath Trust.

One source mentions "a gate near Chalkers Lane", near the Hurstpierpont end of the Trust but this does not appear on the 1842 tithe map of the parish⁹⁰.

Milestones

None known or reported.

Acknowledgements

The survey and research on which this article is based was a co-operative effort by John Blackwell, Peter Holtham and the author. Their assistance is gratefully acknowledged. My thanks is also extended to Ron Martin who executed the map included.

References

- Sue Berry, "Myth and reality in the representation of resorts – Brighton and the emergence of the 'Prince and fishing village myth' 1770-1824", SAC. Vol 140 (2002) pp 98,101-06
- J Bowen, *A Description of Brighthelmstone* (nd 1783) pp 4,56
- Sue Berry, *Georgian Brighton* (Chichester 2005) pp 75-6
- Wallis (pub), *Brighton as it is* (Brighton 1838) pp 9,94-5; Edmund M. Gilbert, *Brighton : Old Ocean's Bauble* (1954) p119
- Wallis(pub), *Brighton as it is* (Brighton 1840) pp 33,53
- Wilfred Hooper, *Reigate: Its Story Through the Ages* (Dorking 1979) pp 85-86
- Ibid.*, pp 88; 1" OS map 1811; *Surrey Investigations – Reigate and Redhill* (Chertsey 1990); SRO 85/2/4/1 No 109
- Hooper *op cit.* pp 88-9
- Ibid.* pp 90-1; SRO 85/2/4/1 No 109; 68/5/121; *Surrey Investigation, op cit*
- BPP 1840 (280) Appendix to the Report of the Commissioners for Enquiring into the State of the Roads
- Martyn Goff, *Victorian and Edwardian Surrey from Old Photographs* (1972) No. 114
- Keith Harding, *Reigate & Redhill Past and Present* (Stroud 1988) p22
- John King, *Gatwick : the Evolution of an Airport* (Gatwick & Brighton 1986) pp64-65
- Wilbraham V. Cooper, *A History of the Parish of Cuckfield* (Haywards Heath 1912) pp 184,193
- Brian Short (ed), *A Very Improving Neighbourhood: Burgess Hill* (Burgess Hill 1984) p27
- ESRO QDP/89/1
- ESRO Schiffner 2757
- Cooper *op cit* p189; WSRO Add Ms 51,817; BPP 1851 (18) xlvi, *County Reports to the Secretary of State under the Act 3 & 4 Wm IV* p11
- J.T. Howard Turner, *The London, Brighton & South Coast Railway Vol I* (1977) p142
- BPP 1851 (18) xlvi, *County Reports to the Secretary of State under the Act 3 & 4 Wm I V* p11
- Short *op cit* p28
- 38-39 Vict c194; ESRO SAS/TP4
- H.R. Atree (pub.), *Atree's Topography of Brighton* (Brighton 1809) roads p4; Cooper *op cit.* P189
- ESRO HOW 34/22, 25
- ESRO SAS/TP4; *Brighton & Hove Herald* 20 Jan 1855, 24 March 1855
- Brighton & Hove Herald* 24 March 1855
- ESRO ABE/17H; SAS/TP4
- WSRO TD/E72
- ESRO SAS/TP4, QDP/EW5/433
- WSRO TD/E72; ESRO QDD/89/1
- ESRO QDD/89/1; WSRO TD/E91
- ESRO SAS/TP4; QDD/EW5/435-36; Cooper *op cit* pp 188-89
- WSRO TD/E91; ESRO SAS/TP4
- WSRO TD/E91; ESRO QDD/EW5/431-32; W.A. Dengate, *Slaugham* (Mountfield 1929) p96; Roger Ray, *Around Old Slaugham* (Handcross 1987) p39
- ESRO QPP/E58
- Sussex County Magazine* Vol. 20 No. 3 March 1946; Charles Harper, *The Brighton Road* (3rd edn 1922) p195
- ESRO SAS/TP4; QDD/EW5/437-38
- Peter Gwynne, *A History of Crawley* (Chichester 1990) p86; Wayfarer Denman, *Crawley Revisted* (Crawley 1993) pp 119-21; ESRO QDD/EW5/425-25, SAS/TP4
- WSRO TD/E91; Cooper *op cit* p189; ESRP SAS/TP4
- WSRO TD/E10; ESRO QDD/EW5/423-24; Observations by the late Frank Gregory in October 1937

41. WSRO TD/W154; ESRO QDD/EW5/429-30
42. WSRO TD/W142; ESRO QDD/EW5/427-28; K.M. Goward, "Transport" in *West Grinstead* (nd) West Sussex Archives Society p 1
43. Gwyneth Pennethorne, "The Tollgates of Sussex", *Sussex County Magazine* Vol 14 No 8 pp 267-72
44. ESRO SAS/TP4
45. 10 Geo III c76
46. 48 Geo III c18
47. *Pigot and Co's National and Commercial Directory* (1839)
48. J. Gregory, *A Description of Brighthelmstone* (1793) p99
49. ESRO DB/P73/6
50. 11 Geo IV c18
51. BPP. *Abstract of Returns ... respecting Turnpike Road Trusts for the year 1829* (1833); *County Reports ... under the Act 3 & 4 Wm. IV c80* (1852) p12; 47-48 Vict c52
52. ESRO QDD/88/1; Letter from Jeremy Hodgkinson of Crawley Down dated 3 January 1977
53. WRSO Add Ms 35664, 35665
54. ESRO. QDD/EW5/533-34
55. WSRO TD/E155; ESRO QDP/88/1; Eric Dawes, *Crossroads Village* (Turners Hill 2000) pp 4,7
56. WSRO TD/E32; ESRO QDD/EW5/225-26
57. WSRO TD/E21, PH 9294; Helena Hall, *Lindfield Past and Present* (Haywards Heath 1960) pp70-72; James S. Gray, *Victorian and Edwardian Sussex from Old Photographs* (1973) pl. 60
58. WSRO TD/E23; ESRO QDD/EW5/535-36
59. Heather Warne (ed), *Wivelsfield: The History of a Wealden Parish* (Hurstpierpoint 1994) p172
60. ESRO TD/E103, QDD/EW5/527-28; Henry Cheal, *The History of Ditchling* (1901) pp48-50
61. ESRO TD/E103; QDD/EW5/529-31; William Gardner and Thomas Gream, *Sussex map 1795*
62. ESRO TD/E/46, HOW 34/19/40, QDD/EW5/529-31; A.S. Cook, *Off the Beaten Track in Sussex* (1911) p251
63. WSRO TD/E77; ESRO QDD/EW5/523-24
64. A. Crawford (publ.), *A Description of Brighthelmstone* (Brighton 1788) pp70-71; F.G. Fisher (publ.), *Description of Brighthelmstone* (Brighton nd 1800) pp82-83
65. ESRO HOW 34/19; Baxter & Co. (pub.), *The Stranger in Brighton* (Brighton 1822, 1824)
66. WSRO Add Ms 30,333
67. BPP 1833(703)xv. 409 *Abstracts of Returns* p239-47; 1851 (18) xlvi County Reports to the Secretary of State No 3, No 6 Sussex pp 19,27
68. WSRO TD/W167
69. WSRO TD/104,Add Ms30,333
70. WSRO TD/E114, TD/E115
71. Add Ms 30,333; information provided to the author by the late Frank Gregory
72. Berry *op cit* p78-80, 110
73. William Albert, *The Turnpike Road System in England 1663-1840* (1972) p79
74. ESRO QDP/E99
75. ESRO QDP/E158
76. WSRO Danny 2093; BPP 1839 (295) ix 369, 1851 (18) xlvi
77. WSRO TD/E70
78. WSRO TD/E11
79. ESRO QDP/89/1, QDP/158; WSRO TD/E44
80. WSRO TD/E10; Pennythorne *op cit* p272
81. WSRO TD/E91; Roger Ray, *Handcross Over the Years* (Handcross 1991) p47
82. Ian D. Margary, "Alterations to the Horley – Balcombe Road in the Coaching Era". *Sussex Notes & Queries* Vol XII pp 105-06
83. BPP 1833(703)xv 409, 1851 (18) xlvi; WSRO Par 801/12/4/133-34; Leslie Fairweather, *Balcombe: The Story of a Sussex Village* (Balcombe 1981) p24; Baxter *op cit*.
84. W.H.Chouher, *Horley: Pagent of a Wealden Parish* (nd c1952) p44
85. WSRO TD/E155
86. *Ibid.*
87. WSRO TD/E91; Pennethorne *op cit* p269
88. Peter Gwynne, *A History of Crawley* (Chichester 1990) p94
89. E.J. Colgate, *The Power and the Poverty: Life in a Sussex Village 1790-1850* (Winchester 2008) p238; BPP 1840 (280) xxvii 15, 1851 (18) xlvi.
90. WSRO TD/E91; Ian Nelson(ed), *Hurstpierpoint – Kind and Charitable* (Hurstpierpoint 2001) p249



Bolney tollhouse relocated to Warninglid

PUBLICATIONS

Previous numbers of *Sussex Industrial History* still available:-

- No. 2 (1971) Dolphin Motors of Shoreham; Lime Kilns in Central Sussex.
 No. 3 (1971/2) Lewes Population 1660-1880; Kingston Malthouse.
 No. 5 (1972/3) East Sussex Milestones; West Brighton Estate; A Bridge for Littlehampton 1821-2.
 No. 17 (1986/7) The Bognor Gas, Light & Coke Company Ltd.; Mineral Transport by the Telfer System (Glynde Aerial Railway); Bricks for the Martello Towers in Sussex; Jesse Pumphery, Millwright.
 No. 18 (1988) See *The Windmills and Millers of Brighton* (revised edition), listed at foot of page.
 No. 19 (1989) Leather Industry; Bignor Park Pump; Lowfield Heath Mill; B.M.R. Gearless Car; Wadhurst Forge.
 No. 20 (1990) William Cooper, Millwright; Foredown Hospital; Ford Aerodrome.
 No. 21 (1991) Quick's Garage, Handcross; Punnett's Town Wind Saw Mills; Hollingbury Industrial Estate.
 No. 22 (1992) Swiss Gardens, Shoreham; Brighton Brewers; Mill Bibliography; Beddingham Kiln.
 No. 23 (1993) Sussex Limeworks; Mills of Forest Row; Machine Tool Manufacture; Brook House Estate; Mill Authors.
 No. 24 (1994) Pullinger's Mouse Trap Manufactory; Ice Houses; Forest Row Mills; Lewes Old Bank; Lumley Mill; Estate Industry at the Hyde; Slindon Bread Ovens.
 No. 25 (1995) Ricardo at Shoreham; Windmill Hill Mill; Portslade Brewery; Brighton General Hospital; Bognor Bus Station; Kidbrooke House Farm; Contents *Sussex Industrial History*.
 No. 26 (1996) Eastbourne Buses; Sussex Lidos; The Sea House Hotel; Bishopstone Tide Mill; Mountfield Gypsum; Uckfield Workhouse; Brighton Oven; Medieval Water Mills.
 No. 27 (1997) Sheffield Park Garden; Brighton Tunbridge Ware Industry; Railway Cutting Excavation; Eastbourne Mills; Tunnels of South Heighton; Sussex Lime Kilns.
 No. 29 (1999) Sussex Windmills and their Restoration.
 No. 30 (2000) Balcombe Tunnel; Ditchling Common Workshops; Midhurst Whites; Keymer Brick & Tile.
 No. 32 (2002) Henry Turner, Brickmaker; Crawley Water Company; Tamplins, Brewers; Ifield Steam Mill; Burgess Hill Pug Mill.
 No. 33 (2003) H.A. Waller & Sons; Electrical Generation at High Salvington; C.V.A./Kearney & Trecker; Cocking Lime Works; Nutley Windmill; Longleys at Christs Hospital.
 No. 34 (2004) West Sussex Brewers; Swanbourne Pumphouse; Hammond Family and Mills; Shoreham Cement Works; Pullinger's Registered Designs; Balcombe Road Forge, Crawley.
 No. 35 (2005) Halsted & Sons of Chichester; Swanbourne Pump House, Arundel; Concrete Shipbuilding at Shoreham; Turnpike Roads to Chichester, Petworth and Midhurst
 No. 36 (2006) The British Syphon Company; Turnpike Roads to Arundel, Worthing and Littlehampton; Brewers of East Sussex; West Hill Cliff Railway, Hastings—Engine Room; The Lamp Posts of Ditchling.
 No. 37 (2007) Poynings Mills; Lavington Park Pump House; Tollhouse and Milestone Survey; A Colonel Stephens 'Find'; CVA Eaton Road, Hove; Cowfold and Henfield Turnpike (Part 1).
 No. 38 (2008) Brighton Brewers; Rottingdean Mill; Turnpikes to Horsham; Cowfold and Henfield Turnpike (Part 2); CVA at Coombe Road Brighton.
 No. 39 (2009) Windmill Sweeps in Sussex and Kent; Alfriston Tower Mill; Earnley (Somerley) Windmill; Isfield Water Mills; Duncton Mill.
 No. 40 (2010) Norman & Burt of Burgess Hill; Shipbuilding at West Itchenor; Winding St. Warehouse, Hastings; Midhurst North Mill; Turnpikes to Steyning, Henfield & Shoreham.

Issues 2, 3 and 5 £1 each, issue 17 £1.50, issues 19, 21 and 22 £2.25 each, issues 23 and 24 £2.50 each, issues 25 and 26 £2.75 each, issues 27 and 28 £2.95 each, issues 29, 30, 32, 33 and 34 £3.95 each, issues 35, 36, 37, 38, 39 and 40 £4.25 each. Post and packing extra, 90p for one copy plus 55p for each subsequent copy. For a list of the articles in volumes no longer available for sale see *Sussex Industrial History* 25 (1995). The Honorary Secretary is prepared to quote for photocopying articles in these issues.

Also available:-

- M. Beswick, *Brickmaking in Sussex* (revised edn 2001) £12.95 post free
 F. Gregory, *A Sussex Water Mill Sketchbook* £6.95 post free
 H. T. Dawes, *The Windmills and Millers of Brighton* (2nd edn.) £4.95 (£5.50 incl. post & packing)
 Alan H. J. Green, *The History of Chichester's Canal* (new edn.) £7.50 (£8.50 incl. post & packing)

Orders with remittance to:-

R.G. Martin, 42 Falmer Avenue, Saltdean, Brighton BN2 8FG Tel. 01273 271330 email: sias@ronmartin.org.uk



The surviving cottages at Ford built to house the engine and lock-keepers
(Alan Green)



Airbus A380 on a visit to San Francisco International Airport



Bolney tollhouse relocated to Warninglid